

Medium Voltage Network Components

Splices, Terminations and Other Industrial &
Construction Cable Accessories



Table of Contents

ColdFit™ Medium Voltage Cold Shrink Terminations..... 3

MV AIRGUARD™ Terminations 7

MV Armored Terminations.....8

MV 3C Airbag / Non-Armored Terminations.....9

5-25kV ELASPEED™ Compact Splice.....10

5-35kV ELASPEED™ Splice 12

Shearbolt® Connectors14

600A/900A Deadbreak Series (15kV/25kV) 17

600A/900A Deadbreak Series (35kV) 21

Cable Preparation Tools..... 25

ColdFit™ Medium Voltage Cold Shrink Terminations



SPECIFICATIONS AND RATINGS

IEEE: IEEE 48 CLASS 1
RUS Listed

DESIGN FEATURES

UNIT CONSTRUCTION

Both the silicone polymer housing and the stress relief material are assembled on a spiral support tube. This enables the installer to apply the termination on the cable with a high degree of ease and accuracy. The top mastic seal is built into the ColdFit™ termination.

EXTERNAL HOUSING

The silicone polymer housing has a superior memory along with excellent tracking and weathering resistance.

STRESS CONTROL

Stress control is maintained using a material with a high permittivity constant (High K), which provides a uniform stress relief in critical areas.

RANGE-COVERING CAPABILITY

The PCT and PICT terminations cover a broad range of cable sizes and voltages with the fewest number of units.

SHED DESIGN

Three designs for superior performance under all conditions.

- Four sheds for 15KV outdoor.
- Four sheds for 25/28KV outdoor.
- Eight sheds for 35KV outdoor.

INSTALLATION

The PCT and the PICT series are designed to give consistent proper positioning of the unit. Additionally, the pull down base gives greater flexibility and sealing when used on jacketed concentric neutral cables.

DESCRIPTION

Prysmian offers a new line of indoor and outdoor polymer terminations available for 5kV, 15KV, 25/28KV and 35KV applications. The ColdFit™ outdoor PCT (with sheds) and indoor PICT (without sheds) are medium voltage cold shrink polymer terminations designed for fast, easy and reliable installation.

The new ColdFit™ terminations shrink evenly on the cable as the inner support core is removed. The top mastic water seal is built into the ColdFit™ termination. No complicated assembly or heat is required. Simply pull out the support core and allow the termination to shrink in order to create a tight void free interface between the termination and the cable. This also provides a superior moisture seal.

All of the Prysmian PCT and PICT terminations meet or exceed the stringent requirements mandated by the IEEE standard 48 for class 1 specification and can operate continuously at 105° C.

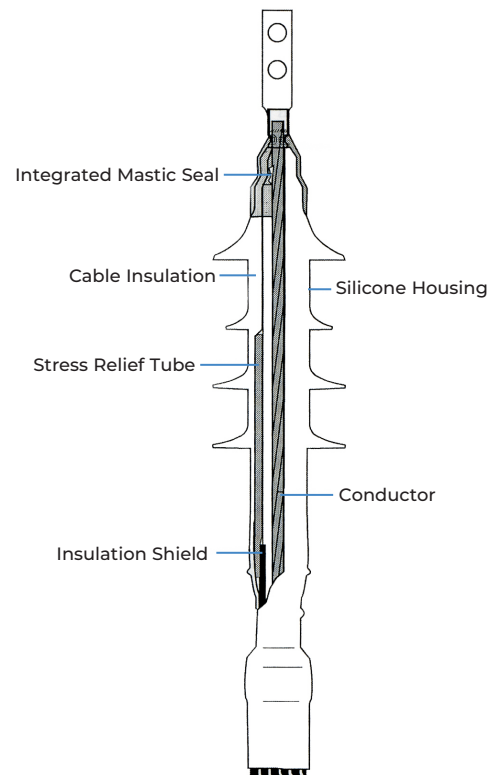

ColdFit™ Medium Voltage Cold Shrink Terminations



Technical Specifications

Type	PCT15	PCT25	PCT35	PICT15
Sizes Available *	1,2,3,5,6	2,3,5,6	3, 5,6	1,2,3,5,6
Voltage Rating (kV)	15	25/28	35	15
Number of Sheds	4	4	8	0
Minimum Strike Distance (In)	11.6	14.5	16.8	8.4
Creepage Distance (In)	15.0	22.8	30.0	8.4
Max. Design Voltage to Ground (kV)	9.5	16	22	9.5
(Partial Discharge)	13	21	30	13
Lightning Impulse (BIL)	110	150	200	110
10 Sec Wet (60 Hz) (kV)	45	60	80	--
1 Minute Dry (60 Hz) (kV)	50	65	90	50
6 Hour Dry (60 Hz) (kV)	35	55	75	35
DC Withstand 15 Min. Dry (kV)	75	105	140	75

Ease of Installation

1. Final Cable Prep

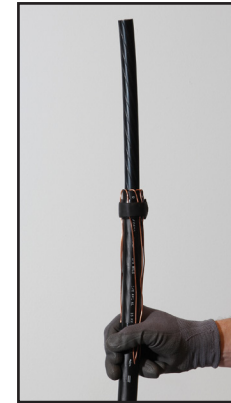

2. Placement of Termination



3. Support Core Removal



4. Completed Assembly

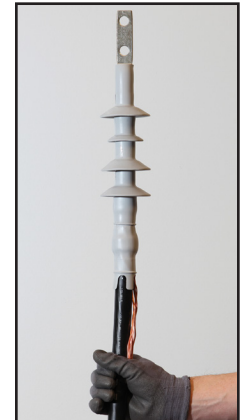

Stress Distribution

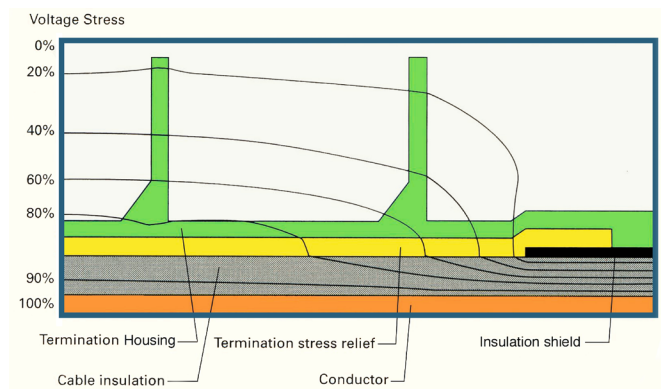

The PCT and PICT terminations provide electrical stress control by utilizing a flexible tube with a high permittivity dielectric constant. The stress relief tube is pre-assembled under the polymer housing. As the core is removed, both the tube and the housing shrink onto the cable in exactly the right position. When energized the electrical field is refracted through the stress relief tube and housing as shown above. The mastic top seal is integrated into the termination body.

PRODUCT NOTES:

The above dimensions are approximate and subject to normal manufacturing tolerances.

All metric (SI) dimensions are derived from a soft conversion.

*Cable dimensions per AIEC CS8, compressed conductor. For all other constructions, verify that actual dimensions of the cable fall within Insulation Diameter tolerances.



Prysmian

4 Tesseneer Drive, Highland Heights, KY 41076
na.prysmian.com
ACS-DS-0008-0624

ColdFit™ Medium Voltage Cold Shrink Terminations



Ordering Information

ColdFit Indoor Terminations - 5kV to 15kV

Part No.	Cable Range (Insulation Diameter)		# of Sheds	5kV 100%	5kV 133% / 8kV 100%	8kV 133%	15kV 100%	15kV 133%
PICT15X1-CF	0.57" to 0.98"	14.5 mm to 25 mm	None	1/0 to 3/0	#1 AWG to 3/0	#1 AWG to 3/0	#2 AWG to 3/0	#2 AWG to 3/0
PICT15X2-CF	0.67" to 1.10"	17 mm to 28 mm	None	4/0 to 250 kcm	3/0 to 250 kcm	1/0 to 250 kcm	#1 AWG to 250 kcm	#2 AWG to 250 kcm
PICT15X3-CF	0.85" to 1.50"	21.5 mm to 38 mm	None	350 kcm to 500 kcm	250 kcm to 500 kcm	4/0 to 500 kcm	4/0 to 500 kcm	2/0 to 500 kcm
PICT15X5-CF	1.08" to 1.97"	27.5 mm to 50 mm	None	750 kcm to 1000 kcm	750 kcm to 1000 kcm	500 kcm to 1000 kcm	350 kcm to 750 kcm	350 kcm to 750 kcm
PICT15X6-CF	1.41" to 2.56"	36 mm to 65 mm	None	Larger Conductor Sizes Available	Larger Conductor Sizes Available	Larger Conductor Sizes Available	1000 to 1500kcm	1000kcm to 1500kcm

ColdFit Outdoor Terminations - 5kV to 15kV

Part No.	Cable Range (Insulation Diameter)		# of Sheds	5kV 100%	5kV 133% / 8kV 100%	8kV 133%	15kV 100%	15kV 133%
PCT15X1-CF	0.57" to 0.98"	14.5 mm to 25 mm	4	1/0 to 3/0	#1 AWG to 3/0	#1 AWG to 3/0	#2 AWG to 3/0	#2 AWG to 3/0
PCT15X2-CF	0.67" to 1.10"	17 mm to 28 mm	4	4/0 to 250 kcm	3/0 to 250 kcm	1/0 to 250 kcm	#1 AWG to 250 kcm	#2 AWG to 250 kcm
PCT15X3-CF	0.85" to 1.50"	21.5 mm to 38 mm	4	350 kcm to 500 kcm	250 kcm to 500 kcm	4/0 to 500 kcm	4/0 to 500 kcm	2/0 to 500 kcm
PCT15X5-CF	1.08" to 1.97"	27.5 mm to 50 mm	4	750 kcm to 1000 kcm	750 kcm to 1000 kcm	500 kcm to 1000 kcm	350 kcm to 1000 kcm*	350 kcm to 1000 kcm*
PCT15X6-CF	1.41" to 2.56"	36 mm to 65 mm	4	Larger Conductor Sizes Available	Larger Conductor Sizes Available	Larger Conductor Sizes Available	1000 to 1500 kcm	1000 kcm to 1500 kcm

Replace X with J for Jacketed Concentric Neutral Cables

Replace X with M for Copper Tape Shielded Cables

Replace X with L for LC Shielded Cables

* For Copper Lugs

The Prysmian Terminations can also be supplied with:

- Copper or aluminum lugs - (1 hole or 2 hole)
- Copper or aluminum pin terminals and also Bi-metallic pin terminals



Prysmian

4 Tessenere Drive, Highland Heights, KY 41076
na.prysmian.com
ACS-DS-0008-0624

ColdFit™ Medium Voltage Cold Shrink Terminations



ColdFit Outdoor Terminations - 25kV to 28kV 133%

Part No.	Cable Range (Insulation Diameter)		# of Sheds	25kV 100%	25kV 133% / 28kV 100%	28kV 133%
PCT25X2-CF4	0.67" to 1.10"	17 mm to 28 mm	4	#2 AWG to 2/0 AWG	#2 AWG to 2/0 AWG	#2 AWG to #1 AWG
PCT25X3-CF4	0.85" to 1.50"	21.5 mm to 38 mm	4	3/0 AWG to 350 kcm	3/0 to 250 kcm	1/0 to 250 kcm
PCT25X5-CF4	1.08" to 1.97"	27.5 mm to 50 mm	4	250 kcm to 1000 kcm	3/0 to 800 kcm	2/0 to 800 kcm
PCT25X6-CF4	1.41" to 2.56"	36 mm to 65 mm	4	750 kcm to 1500 kcm	500 kcm to 1500 kcm	500 kcm to 1500 kcm

ColdFit Outdoor Terminations - 35kV

Part No.	Cable Range (Insulation Diameter)		# of Sheds	35kV 100%	35kV 133%
PCT35X3-CF	0.85" to 1.35"	21mm to 34mm	8	1/0 AWG to 2/0 AWG	1/0 AWG
PCT35X5-CF	1.08" to 1.70"	27.5 mm to 41 mm	8	1/0 AWG* to 500 kcm	2/0 AWG to 350 kcm
PCT35X6-CF	1.41" to 2.20"	36 mm to 56 mm	8	400 kcm to 1500 kcm	250 kcm to 1250 kcm

* For this size termination a shear bolt lug with outer diameter of 1.25" should be used on 1/0-4/0 AWG cables to create a tight seal at the top of the termination.

Replace **X** with J for Jacketed Concentric Neutral Cables

Replace **X** with M for Copper Tape Shielded Cables

Replace **X** with L for LC Shielded Cables

The Prysmian Terminations can also be supplied with:

- Copper or Bi-metallic lugs (2 hole Crimp or shear bolt design option)
- Copper or Bi-metallic pin terminals (Crimp or shear bolt design option)

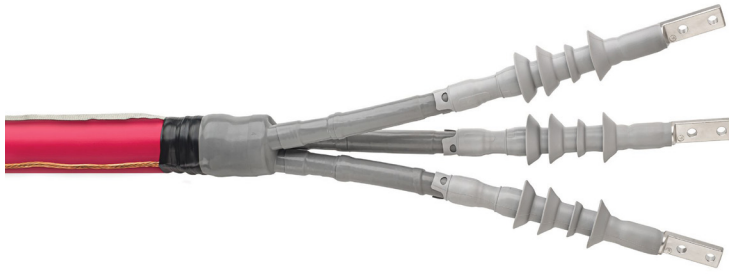

DESCRIPTION

Prysmian Group's patented AIRGUARD™ cable is a superior replacement for CCW type armored cables. Prysmian has developed a quick and easy termination for AIRGUARD™ cable. Two-hole lugs can be provided so that a complete kit is ready for the jobsite.

Add "-O" to below product number for outdoor or "-I" for indoor termination kits. If not specified, outdoor rated terminations will be assumed as requested.

Break Out Kits contain all the components needed to prepare the 3/C Cable to install a termination (no termination included).

RUS Listed.

1/C 5kV Terminations (Indoor or Outdoor)

Termination Kit	Cable Range	Insulation OD
AGT1C5HS	#2 AWG - #1 AWG	0.35" - 0.60"
AGT1CA5-X	1/0 AWG - 3/0 AWG	0.57" - 0.98"
AGT1CB5-X	4/0 AWG - 250 kcmil	0.67" - 1.10"
AGT1CC5-X	350 kcmil - 500 kcmil	0.85" - 1.50"
AGT1CD5-X	750 kcmil - 1000 kcmil	1.08" - 1.97"
AGT1CE5-X	Larger Size	1.41" - 2.56"

3/C 5kV Terminations (Indoor or Outdoor)

Termination Kit	Cable Range	Insulation OD
AGT3C5HS	#2 AWG - #1 AWG	0.35" - 0.60"
AGT3CA5-X	1/0 AWG - 3/0 AWG	0.57" - 0.98"
AGT3CB5-X	4/0 AWG - 250 kcmil	0.67" - 1.10"
AGT3CC5-X	350 kcmil - 500 kcmil	0.85" - 1.50"
AGT3CD5-X	750 kcmil - 1000 kcmil	1.08" - 1.97"
AGT3CE5-X	Larger Size	1.41" - 2.56"

1/C 15kV Terminations (Indoor or Outdoor)

Termination Kit	Cable Range	Insulation OD
AGT1CA15-X	#2 AWG - 3/0 AWG	0.57" - 0.98"
AGT1CB15-X	#1 AWG - 250 kcmil	0.67" - 1.10"
AGT1CC15-X	2/0 AWG - 500 kcmil	0.85" - 1.50"
AGT1CD15-X	350 kcmil - 750 kcmil	1.08" - 1.97"
AGT1CE15-X	1000 kcmil - 1500 kcmil	1.41" - 2.56"

3/C 15kV Terminations (Indoor or Outdoor)

Termination Kit	Cable Range	Insulation OD
AGT3CA15-X	#2 AWG - 3/0 AWG	0.57" - 0.98"
AGT3CB15-X	#1 AWG - 250 kcmil	0.67" - 1.10"
AGT3CC15-X	2/0 AWG - 500 kcmil	0.85" - 1.50"
AGT3CD15-X	350 kcmil - 750 kcmil	1.08" - 1.97"
AGT3CE15-X	1000 kcmil - 1500 kcmil	1.41" - 2.56"

1/C 25kV Terminations (Outdoor Only)

Termination Kit	Cable Range	Insulation OD
AGT1CB25-O	#2 AWG - 2/0 AWG	0.67" - 1.10"
AGT1CC25-O	3/0 AWG - 250 kcmil	0.85" - 1.50"
AGT1CD25-O	350 kcmil - 750 kcmil	1.08" - 1.97"
AGT1CE25-O	500 kcmil - 1500 kcmil	1.41" - 2.56"

3/C 25kV Terminations (Outdoor Only)

Termination Kit	Cable Range	Insulation OD
AGT3CB25-O	#2 AWG - 2/0 AWG	0.67" - 1.10"
AGT3CC25-O	3/0 AWG - 250 kcmil	0.85" - 1.50"
AGT3CD25-O	350 kcmil - 750 kcmil	1.08" - 1.97"
AGT3CE25-O	500 kcmil - 1500 kcmil	1.41" - 2.56"

1/C 35kV Terminations (Outdoor Only)

Termination Kit	Cable Range	Insulation OD
AGT1CC35-O	1/0 AWG - 4/0 AWG	0.67" - 1.10"
AGT1CD35-O	250 kcmil - 350 kcmil	0.85" - 1.50"
AGT1CE35-O	500 kcmil - 750 kcmil	1.08" - 1.97"
AGT1CF35-O	750 kcmil - 1000 kcmil	1.41" - 2.56"

3/C 35kV Terminations (Outdoor Only)

Termination Kit	Cable Range	Insulation OD
AGT3CC35-O	1/0 AWG - 4/0 AWG	0.67" - 1.10"
AGT3CD35-O	250 kcmil - 350 kcmil	0.85" - 1.50"
AGT3CE35-O	500 kcmil - 750 kcmil	1.08" - 1.97"
AGT3CF35-O	750 kcmil - 1000 kcmil	1.41" - 2.56"

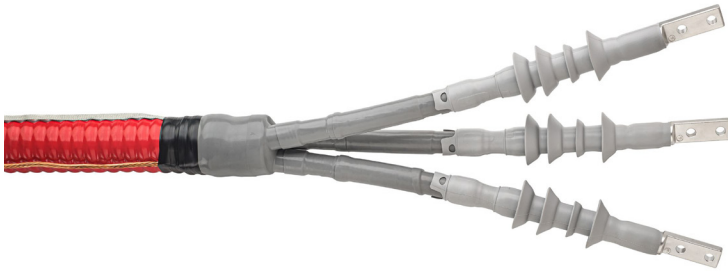

DESCRIPTION

Prysmian has developed a quick and easy termination for ARMORED cable.

Two-hole lugs can be provided so that a complete kit is ready for the jobsite.

Add "-O" to below product number for outdoor or "-I" for indoor termination kits. If not specified, outdoor rated terminations will be assumed as requested.

Break Out Kits contain all the components needed to prepare the 3/C Cable to install a termination (no termination included).

RUS Listed.

1/C 5kV Terminations (Indoor or Outdoor)

Termination Kit	Cable Range	Insulation OD
AT1C5HS	#2 AWG - #1 AWG	0.35" - 0.60"
AT1CA5-X	1/0 AWG - 3/0 AWG	0.57" - 0.98"
AT1CB5-X	4/0 AWG - 250 kcmil	0.67" - 1.10"
AT1CC5-X	350 kcmil - 500 kcmil	0.85" - 1.50"
AT1CD5-X	750 kcmil - 1000 kcmil	1.08" - 1.97"
AT1CE5-X	Larger Size	1.41" - 2.56"

3/C 5kV Terminations (Indoor or Outdoor)

Termination Kit	Cable Range	Insulation OD
AT3C5HS	#2 AWG - #1 AWG	0.35" - 0.60"
AT3CA5-X	1/0 AWG - 3/0 AWG	0.57" - 0.98"
AT3CB5-X	4/0 AWG - 250 kcmil	0.67" - 1.10"
AT3CC5-X	350 kcmil - 500 kcmil	0.85" - 1.50"
AT3CD5-X	750 kcmil - 1000 kcmil	1.08" - 1.97"
AT3CE5-X	Larger Size	1.41" - 2.56"

1/C 15kV Terminations (Indoor or Outdoor)

Termination Kit	Cable Range	Insulation OD
AT1CA15-X	#2 AWG - 3/0 AWG	0.57" - 0.98"
AT1CB15-X	#1 AWG - 250 kcmil	0.67" - 1.10"
AT1CC15-X	2/0 AWG - 500 kcmil	0.85" - 1.50"
AT1CD15-X	350 kcmil - 750 kcmil	1.08" - 1.97"
AT1CE15-X	1000 kcmil - 1500 kcmil	1.41" - 2.56"

3/C 15kV Terminations (Indoor or Outdoor)

Termination Kit	Cable Range	Insulation OD
AT3CA15-X	#2 AWG - 3/0 AWG	0.57" - 0.98"
AT3CB15-X	#1 AWG - 250 kcmil	0.67" - 1.10"
AT3CC15-X	2/0 AWG - 500 kcmil	0.85" - 1.50"
AT3CD15-X	350 kcmil - 750 kcmil	1.08" - 1.97"
AT3CE15-X	1000 kcmil - 1500 kcmil	1.41" - 2.56"

1/C 25kV Terminations (Outdoor Only)

Termination Kit	Cable Range	Insulation OD
AT1CB25-O	#2 AWG - 2/0 AWG	0.67" - 1.10"
AT1CC25-O	3/0 AWG - 250 kcmil	0.85" - 1.50"
AT1CD25-O	350 kcmil - 750 kcmil	1.08" - 1.97"
AT1CE25-O	500 kcmil - 1500 kcmil	1.41" - 2.56"

3/C 25kV Terminations (Outdoor Only)

Termination Kit	Cable Range	Insulation OD
AT3CB25-O	#2 AWG - 2/0 AWG	0.67" - 1.10"
AT3CC25-O	3/0 AWG - 250 kcmil	0.85" - 1.50"
AT3CD25-O	350 kcmil - 750 kcmil	1.08" - 1.97"
AT3CE25-O	500 kcmil - 1500 kcmil	1.41" - 2.56"

1/C 35kV Terminations (Outdoor Only)

Termination Kit	Cable Range	Insulation OD
AT1CC35-O	1/0 AWG - 4/0 AWG	0.67" - 1.10"
AT1CD35-O	250 kcmil - 350 kcmil	0.85" - 1.50"
AT1CE35-O	500 kcmil - 750 kcmil	1.08" - 1.97"
AT1CF35-O	750 kcmil - 1000 kcmil	1.41" - 2.56"

3/C 35kV Terminations (Outdoor Only)

Termination Kit	Cable Range	Insulation OD
AT3CC35-O	1/0 AWG - 4/0 AWG	0.67" - 1.10"
AT3CD35-O	250 kcmil - 350 kcmil	0.85" - 1.50"
AT3CE35-O	500 kcmil - 750 kcmil	1.08" - 1.97"
AT3CF35-O	750 kcmil - 1000 kcmil	1.41" - 2.56"

MV 3C Airbag / Non-Armored Terminations



DESCRIPTION

Prysmian has developed a quick and easy termination for 3/C under common Jacket Uniblend cable.

Two-hole lugs can be provided so that a complete kit is ready for the jobsite.

Add "-O" to below product number for outdoor or "-I" for indoor termination kits. If not specified, outdoor rated terminations will be assumed as requested.

Break Out Kits included in the termination solution contain all the components needed to prepare the 3/C Cable to install a termination (no termination included).

RUS Listed.

1/C 5kV Terminations (Indoor or Outdoor)

Termination Kit	Cable Range	Insulation OD
ABT1C5HS	#2 AWG - #1 AWG	0.35" - 0.60"
ABT1CA5-X	1/0 AWG - 3/0 AWG	0.57" - 0.98"
ABT1CB5-X	4/0 AWG - 250 kcmil	0.67" - 1.10"
ABT1CC5-X	350 kcmil - 500 kcmil	0.85" - 1.50"
ABT1CD5-X	750 kcmil - 1000 kcmil	1.08" - 1.97"
ABT1CE5-X	Larger Size	1.41" - 2.56"

3/C 5kV Terminations (Indoor or Outdoor)

Termination Kit	Cable Range	Insulation OD
ABT3C5HS	#2 AWG - #1 AWG	0.35" - 0.60"
ABT3CA5-X	1/0 AWG - 3/0 AWG	0.57" - 0.98"
ABT3CB5-X	4/0 AWG - 250 kcmil	0.67" - 1.10"
ABT3CC5-X	350 kcmil - 500 kcmil	0.85" - 1.50"
ABT3CD5-X	750 kcmil - 1000 kcmil	1.08" - 1.97"
ABT3CE5-X	Larger Size	1.41" - 2.56"

1/C 15kV Terminations (Indoor or Outdoor)

Termination Kit	Cable Range	Insulation OD
ABT1CA15-X	#2 AWG - 3/0 AWG	0.57" - 0.98"
ABT1CB15-X	#1 AWG - 250 kcmil	0.67" - 1.10"
ABT1CC15-X	2/0 AWG - 500 kcmil	0.85" - 1.50"
ABT1CD15-X	350 kcmil - 750 kcmil	1.08" - 1.97"
ABT1CE15-X	1000 kcmil - 1500 kcmil	1.41" - 2.56"

3/C 15kV Terminations (Indoor or Outdoor)

Termination Kit	Cable Range	Insulation OD
ABT3CA15-X	#2 AWG - 3/0 AWG	0.57" - 0.98"
ABT3CB15-X	#1 AWG - 250 kcmil	0.67" - 1.10"
ABT3CC15-X	2/0 AWG - 500 kcmil	0.85" - 1.50"
ABT3CD15-X	350 kcmil - 750 kcmil	1.08" - 1.97"
ABT3CE15-X	1000 kcmil - 1500 kcmil	1.41" - 2.56"

1/C 25kV Terminations (Outdoor Only)

Termination Kit	Cable Range	Insulation OD
ABT1CB25-O	#2 AWG - 2/0 AWG	0.67" - 1.10"
ABT1CC25-O	3/0 AWG - 250 kcmil	0.85" - 1.50"
ABT1CD25-O	350 kcmil - 750 kcmil	1.08" - 1.97"
ABT1CE25-O	500 kcmil - 1500 kcmil	1.41" - 2.56"

3/C 25kV Terminations (Outdoor Only)

Termination Kit	Cable Range	Insulation OD
ABT3CB25-O	#2 AWG - 2/0 AWG	0.67" - 1.10"
ABT3CC25-O	3/0 AWG - 250 kcmil	0.85" - 1.50"
ABT3CD25-O	350 kcmil - 750 kcmil	1.08" - 1.97"
ABT3CE25-O	500 kcmil - 1500 kcmil	1.41" - 2.56"

1/C 35kV Terminations (Outdoor Only)

Termination Kit	Cable Range	Insulation OD
ABT1CC35-O	1/0 AWG - 4/0 AWG	0.67" - 1.10"
ABT1CD35-O	250 kcmil - 350 kcmil	0.85" - 1.50"
ABT1CE35-O	500 kcmil - 750 kcmil	1.08" - 1.97"
ABT1CF35-O	750 kcmil - 1000 kcmil	1.41" - 2.56"

3/C 35kV Terminations (Outdoor Only)

Termination Kit	Cable Range	Insulation OD
ABT3CC35-O	1/0 AWG - 4/0 AWG	0.67" - 1.10"
ABT3CD35-O	250 kcmil - 350 kcmil	0.85" - 1.50"
ABT3CE35-O	500 kcmil - 750 kcmil	1.08" - 1.97"
ABT3CF35-O	750 kcmil - 1000 kcmil	1.41" - 2.56"



DESIGN FEATURES

UNIFORM CUTBACK DIMENSIONS

The Elaseed™ Compact Splice is expanded to allow 'parking' on one side of the splice area, over the cable jacket. Installer errors during cable preparation are minimized, because cutbacks for jacket, shield, semiconductor and insulation are identical for both cables to be spliced.

WATERTIGHT INSTALLATION

Major accessory users are concerned that ingress of water in damaged cable jackets and unsealed splices can lead to premature failures. The Elaseed™ Compact Splice has successfully passed IEEE 404-2012, the industry standard for splices. The Elaseed™ Compact Splice has passed external water pressure tests of 45 psi. In addition, the tight interface between the cable and splice body can withstand internal pressures up to 30 psi. Internal mastic seals ensure that even cable jacket damage will not allow water to enter the splice area.

SMALL PROFILE

Elaseed™ Compact Splices behave like EPR cable when it comes to bending in tight manhole situations. Splices can be bent to the same radius as the cable on which it is applied. This small profile consumes less racking space as well.

RANGE-TAKING CAPABILITY

The splice can easily accommodate different types of insulation (EPR to XLPE), different insulation thicknesses (175 mil to 220 mil, or 260 mil to 345 mil), as well as different conductor sizes and metals.

DESCRIPTION

The new Elaseed™ Compact Splice (25% shorter in length) is a low-profile, range-taking, 105°C-operating-temperature cable splice. It is designed to splice tape shield, wire shield, LC shield, UniShield, JCN and flat strap shielded cables. Compact structure allows for installation in confined areas and requires less cable to be prepared. The insulation is made from ethylene propylene rubber (EPR) on a vertical triple extruder which maintains its concentricity to tight tolerances. It is tested as a cable (partial discharge and AC withstand) to ensure long and trouble-free operation under a wide variety of applications and conditions. Elaseed Compact Splices are suitable for installation in aerial, direct bury, duct bank and manhole environments. If installed in an aerial environment, a serve wire or basket support should be utilized to support the weight of the cable.

RUS Listed.

WHY USE ELASPEED™ COMPACT SPLICES?

25% SHORTER

Elaseed™ Compact Splices are 25% shorter in length which makes it easier to park in tight manholes, requires less cable to prepare and reduces storage space over traditional splice kits.

SPEED

An Elaseed™ Compact Splice can be performed in 30 minutes or less, saving time and money over other splices.

TESTING

All Elaseed™ Compact Splices are pre-tested as cable to ensure that the splice will maintain the integrity of the electrical system. The Elaseed™ EPR insulation system provides the highest dielectric strength over the full voltage range as well as the highest BIL available from any splice technology.

SAFETY

Elaseed™ Compact Splices utilize cold shrink technology, which requires no open flames, eliminating the problems associated with handling and transporting gas bottles

RELIABILITY AND REPEATABILITY

Elaseed™ Compact Splices are reliable because they always shrink uniformly, and there is only one part to shrink – the triple-extruded body.

5-25kV ELASPEED™ Compact Splice



Product Number	Cable Range	Shielding Braid Size	Shearbolt Range	Insulation Diameter		Jacket Diameter
				Minimum	Maximum	Maximum
5kV Elspeed™ - 100% Insulation Level (90 mils)						
15SDJCe-C	3/0 - 250	2/0	6-3/0	0.68"	1.13"	1.33"
15SEJCe-C	250 - 500	2/0	2-250	0.76"	1.26"	1.49"
15SFJCe-C	500-750	2/0	1/0-500	0.91"	1.42"	1.88"
15SHJCe-C	500-750	2/0	1/0-500	0.96"	1.57"	1.96"
15SIPJCe-C	500-1000	2/0	350-750	1.09"	1.77"	2.24"
15SIJCe-C	1000-1000	2/0	500-1000	1.26"	2.20"	2.63"
5kV Elspeed™ - 133% Insulation Level (115 mils)						
15SDJCe-C	2/0 - 250	2/0	6-3/0	0.68"	1.13"	1.33"
15SEJCe-C	4/0 - 350	2/0	2-250	0.76"	1.26"	1.49"
15SFJCe-C	350 - 500	2/0	1/0-500	0.91"	1.42"	1.88"
15SHJCe-C	500 - 500	2/0	1/0-500	0.96"	1.57"	1.96"
15SIPJCe-C	750 - 1000	2/0	350-750	1.09"	1.77"	2.24"
15SIJCe-C	1000 - 1000	2/0	500-1000	1.26"	2.20"	2.63"
15kV Elspeed™ - 100% Insulation Level (175 mils)						
15SDJCe-C	2 - 3/0	2/0	6-3/0	0.68"	1.13"	1.33"
15SEJCe-C	1/0 - 250	2/0	2-250	0.76"	1.26"	1.49"
15SFJCe-C	4/0 - 500	2/0	1/0-500	0.91"	1.42"	1.88"
15SHJCe-C	250 - 500	2/0	1/0-500	0.96"	1.57"	1.96"
15SIPJCe-C	250 - 500	2/0	350-750	1.09"	1.77"	2.24"
15SIJCe-C	750 - 1000	2/0	500-1000	1.26"	2.20"	2.63"
15kV Elspeed™ - 133% Insulation Level (220 mils)						
15SDJCe-C	2 - 2/0	2/0	6-3/0	0.68"	1.13"	1.33"
15SEJCe-C	2 - 4/0	2/0	2-250	0.76"	1.26"	1.49"
15SFJCe-C	3/0 - 500	2/0	1/0-500	0.91"	1.42"	1.88"
15SHJCe-C	4/0 - 500	2/0	1/0-500	0.96"	1.57"	1.96"
15SIPJCe-C	350 - 750	2/0	350-750	1.09"	1.77"	2.24"
15SIJCe-C	500 - 1000	2/0	500-1000	1.26"	2.20"	2.63"
25kV Elspeed™ - 100% Insulation Level (260 mils)						
25SDJCe-C	1 - 1/0	2/0	6-3/0	0.68"	1.13"	1.33"
25SEJCe-C	1 - 2/0	2/0	2-250	0.76"	1.26"	1.49"
25SFJCe-C	1/0 - 350	2/0	1/0-500	0.91"	1.42"	1.88"
25SHJCe-C	2/0 - 500	2/0	1/0-500	0.96"	1.57"	1.96"
25SIPJCe-C	250 - 500	2/0	350-750	1.09"	1.77"	2.24"
25SIJCe-C	500 - 1000	2/0	500-1000	1.26"	2.20"	2.63"
25kV Elspeed™ - 133% Insulation Level (320 mils)						
25SDJCe-C	N/A	2/0	6-3/0	0.68"	1.13"	1.33"
25SEJCe-C	N/A	2/0	2-250	0.76"	1.26"	1.49"
25SFJCe-C	1 - 4/0	2/0	1/0-500	0.91"	1.42"	1.88"
25SHJCe-C	1 - 350	2/0	1/0-500	0.96"	1.57"	1.96"
25SIPJCe-C	3/0 - 500	2/0	350-750	1.09"	1.77"	2.24"
25SIJCe-C	350 - 1000	2/0	500-1000	1.26"	2.20"	2.63"
28kV Elspeed™ - 100% Insulation Level (280 mils)						
25SDJCe-C	4 - 2	2/0	6 - 3/0	0.68"	1.13"	1.33"
25SEJCe-C	4 - 3/0	2/0	6 - 3/0	0.76"	1.26"	1.49"
25SFJCe-C	2/0 - 500	2/0	1/0 - 500	0.91"	1.42"	1.88"
25SHJCe-C	3/0 - 650	2/0	Ask Rep.	0.96"	1.57"	1.96"
25SIPJCe-C	300 - 900	2/0	Ask Rep.	1.09"	1.77"	2.24"
25SIJCe-C	500 - 1500	2/0	Ask Rep.	1.26"	2.20"	2.63"
28kV Elspeed™ - 133% Insulation Level (345 mils)						
25SDJCe-C	N/A	2/0	N/A	0.68"	1.13"	1.33"
25SEJCe-C	4 - 1	2/0	6 - 3/0	0.76"	1.26"	1.49"
25SFJCe-C	2 - 250	2/0	2 - 250	0.91"	1.42"	1.88"
25SHJCe-C	1 - 350	2/0	1/0 - 500	0.96"	1.57"	1.96"
25SIPJCe-C	3/0 - 750	2/0	Ask Rep.	1.09"	1.77"	2.24"
25SIJCe-C	350 - 1500	2/0	Ask Rep.	1.26"	2.20"	2.63"

Notes:

1. When selecting kits at the top end of the use range, check for proper fit over jacket
2. The selection guide is based on jacketed concentric neutral cables. When using LC or copper tape shield cables, the range may be extended upwards
3. Prysmian Elspeed™ Compact Splices meet IEEE 404-2012 specifications.
4. Contact your Prysmian sales representative for more information, including data on size transition limits
5. If Crimp Connectors are used Prysmian must verify the length of the crimp connector.

Splice Part Number Designation

Size selection is based on typical URD cable parameters:

- Class B Compressed Round Copper conductor.
- AEIC minimum insulation diameters.
- One-third concentric neutral.
- Concentric neutral wires not being brought out for grounding or fault current protection.
- Encapsulated jacket.
- XLPE or EPR Shielded Power Cable.

If the cable design or installation is based on other parameters, the recommended splice size may change.

The "15" in the splice part number indicates the rated voltage for the splice. Note that 15kV splices are used for 5kV and 8kV. This splice will simply provide more protection for the respective voltage classes.

The "D", "E", "F", "H", "IP" or "I" in the splice part number denotes the size parameter of the splice. All of the splices for 5 thru 28kV have a built in electrode for stress control, which is denoted by the small "e" in the part number.

The "J" in the splice part number indicates a jacketed splice. Splices may be ordered without a jacket, in which case the "J" would not be included in the splice part number.

Splice Selection and Ordering

When selecting splice kits at the top end of the use range, check for proper fit over jacket. If standard splicing practice includes bringing out the neutral wires for grounding and/or fault protection, this will significantly increase the overall diameter of the cable and can change the recommended splice size.



SPECIFICATIONS AND RATINGS

IEEE: IEEE 404
RUS Listed

OPTIONS:

- Alternative shield/neutral connection systems (constant force spring, LC connector, etc.)
- Compression or Shear Bolt connectors in Copper or Aluminum
- Cable Clean Prep Kit that includes Cleaning Pads and Al Oxide Abrasive Cloth (add -PREP to part number)

DESIGN FEATURES

UNIFORM CUTBACK DIMENSIONS

The Elaseed™ Splice is expanded to allow ‘parking’ on one side of the splice area, over the cable jacket. Installer errors during cable preparation are minimized, because cutbacks for jacket, shield, semiconductor and insulation are identical for both cables to be spliced.

WATERTIGHT INSTALLATION

Major accessory users are concerned that ingress of water in damaged cable jackets and unsealed splices can lead to premature failures. The Elaseed splice has successfully passed IEEE 404-1993, the industry standard for splices. The Elaseed splice also passes pressure tests at an external pressure of 45 psi. Internal mastic seals ensure that even cable jacket damage will not allow water to enter the splice area.

SMALL PROFILE

Elaseed™ Splices behave like EPR cable when it comes to bending in tight manhole situations. Splices can be bent to the same radius as the cable on which it is applied. This small profile consumes less racking space as well.

RANGE-TAKING CAPABILITY

The splice can easily accommodate different types of insulation (EPR to XLPE), different insulation thicknesses (175 mil to 220 mil, or 260 mil to 345 mil), as well as different conductor sizes and metals.

DESCRIPTION

Elaseed™ splices utilize cold shrink technology – widely recognized as the leading edge “delivery system” for cable accessories. No special tools or torches are required. Cold shrinking the splice ensures concentric splice recovery. Even in tight installation spaces, Elaseed splices recover to give consistent insulation wall thickness. The Elaseed core, constructed from ethylene propylene rubber (EPR) insulation, is manufactured on a vertical extruder to ensure complete concentricity to the tightest tolerance possible. The Elaseed splice is a “complete” splice, containing the splice core, a shielding braid and a jacket. Elaseed splices are suitable for installation in aerial, direct bury, duct bank and manhole environments. If installed in an aerial environment, a serve wire or basket support should be utilized to support the weight of the cable.

WHY USE ELASPEED™ SPLICES?

SPEED

An Elaseed™ Splice can be performed in 30 minutes or less, saving time and money over other splices.

TESTING

All Elaseed™ Splices are pre-tested as cable to ensure that the splice will maintain the integrity of the electrical system. The Elaseed™ EPR insulation system provides the highest dielectric strength over the full voltage range as well as the highest BIL available from any splice technology.

SAFETY

Elaseed™ Splices utilize cold shrink technology, which requires no open flames, eliminating the problems associated with handling and transporting gas bottles.

RELIABILITY AND REPEATABILITY

Elaseed splices are reliable because they always shrink uniformly, and there is only one part to shrink – the triple-extruded body. Tight manhole spaces can create difficulty in assuring that the multiple layers of heat shrink splices receive adequate heating over the entire cable radius. No matter how many splices must be installed, the last splice will be as reliable as the first. The physical effort associated with push-on and tape splices is eliminated with the simple cold shrink technique.

5-35kV ELASPEED™ Splice



Part Number	Cable Size Range	Shielding Braid Size	Insulation Diameter Min. Inches	Insulation Diameter Max. Inches	Jacket Diameter Max. Inches
5kV - 100% Insulation Level (90mil)					
5SDJBe	3/0 - 250	2/0	0.68"	1.13"	1.34"
5SEJCe	250 - 500	2/0	0.76"	1.26"	1.49"
5SFJCe	500-750	2/0	0.91"	1.42"	1.89"
5SHJCe	500-750	2/0	0.96"	1.57"	1.97"
5SIPJCe	500-1000	2/0	1.09"	1.77"	2.24"
5SIJCe	1000-1000	2/0	1.26"	2.20"	2.64"
5kV - 133% Insulation Level (115 mil)					
5SDJBe	2/0 - 250	2/0	0.68"	1.13"	1.34"
5SEJCe	4/0 - 350	2/0	0.76"	1.26"	1.49"
5SFJCe	350 - 500	2/0	0.91"	1.42"	1.89"
5SHJCe	500 - 500	2/0	0.96"	1.57"	1.97"
5SIPJCe	750 - 1000	2/0	1.09"	1.77"	2.24"
5SIJCe	1000 - 1000	2/0	1.26"	2.20"	2.64"
15kV - 100% Insulation Level (175mil)					
15SDJBe	2 - 3/0	2/0	0.68	1.13	1.34
15SEJCe	1/0 - 250	2/0	0.75	1.26	1.49
15SFJCe	4/0 - 500	2/0	0.91	1.42	1.89
15SHJCe	250 - 500	2/0	0.96	1.57	1.97
15SIPJCe	500 - 750	2/0	1.09	1.77	2.24
15SIJCe	750 - 1000	2/0	1.26	2.20	2.64
15kV - 133% Insulation Level (220 mil)					
15SDJBe	2 - 2/0	2/0	0.68	1.13	1.34
15SEJCe	2 - 4/0	2/0	0.75	1.26	1.49
15SFJCe	3/0 - 500	2/0	0.91	1.42	1.89
15SHJCe	4/0 - 500	2/0	0.96	1.57	1.97
15SIPJCe	350 - 750	2/0	1.09	1.77	2.24
15SIJCe	500 - 1000	2/0	1.26	2.20	2.64
25kV - 100% Insulation Level (260 mil)					
25SDJBe	1 - 1/0	2/0	0.68	1.13	1.34
25SEJCe	1 - 2/0	2/0	0.75	1.26	1.49
25SFJCe	1/0 - 350	2/0	0.91	1.42	1.89
25SHJCe	2/0 - 500	2/0	0.96	1.57	1.97
25SIPJCe	250 - 500	2/0	1.09	1.77	2.24
25SIJCe	500 - 1000	2/0	1.26	2.20	2.64
25kV - 133% Insulation Level (320 mil)					
25SFJCe	1 - 4/0	2/0	0.91	1.42	1.89
25SHJCe	1 - 350	2/0	0.96	1.57	1.97
25SIPJCe	3/0 - 500	2/0	1.09	1.77	2.24
25SIJCe	350 - 1000	2/0	1.26	2.20	2.64
28kV Elasppeed™ - 100% Insulation Level (280 mil)					
25SDJCe-C	4 - 2	2/0	0.68	1.13	1.34
25SEJCe-C	4 - 3/0	2/0	0.76	1.26	1.49
25SFJCe-C	2/0 - 500	2/0	0.91	1.42	1.88
25SHJCe-C	3/0 - 650	2/0	0.96	1.57	1.96
25SIPJCe-C	300 - 900	2/0	1.09	1.77	2.24
25SIJCe-C	500 - 1500	2/0	1.26	2.20	2.63
28kV Elasppeed™ - 133% Insulation Level (345 mil)					
25SDJCe-C	N/A	2/0	0.68	1.13	1.34
25SEJCe-C	4 - 1	2/0	0.76	1.26	1.49
25SFJCe-C	2 - 250	2/0	0.91	1.42	1.88
25SHJCe-C	1 - 350	2/0	0.96	1.57	1.96
25SIPJCe-C	3/0 - 750	2/0	1.09	1.77	2.24
25SIJCe-C	350 - 1500	2/0	1.26	2.20	2.63
35kV - 100% Insulation Level (345 mil)					
35SHJC	1 - 250	2/0	0.96	1.57	1.97
35SIPJC	1/0 - 500	2/0	1.09	1.77	2.24
35SIJC	4/0 - 1000	2/0	1.26	2.20	2.64
35SJJC	1250 - 2000	4/0	1.77	2.83	3.34
35kV - 133% Insulation Level (420 mil)					
35SHJC	1/0 - 3/0	2/0	0.96	1.57	1.96
35SIPJC	1/0 - 350	2/0	1.09	1.77	2.24
35SIJC	2/0 - 750	2/0	1.26	2.20	2.63
35SJJC	1000 - 2000	4/0	1.77	2.83	3.34

Splice Part Number Designation

Size selection is based on typical URD cable parameters:

- Class B Compressed Round Copper conductor.
- AEIC minimum insulation diameters.
- One-third concentric neutral.
- Concentric neutral wires not being brought out for grounding or fault current protection.
- Encapsulated jacket.
- XLPE or EPR Shielded Power Cable.

If the cable design or installation is based on other parameters, the recommended splice size may change.

Notes:

- 1) When selecting kits at the top end of the use range, check for proper fit over jacket. Also consider the increased diameter associated with CN wire folded back over cable jacket.
- 2) The selection guide is based on jacketed concentric neutral cables. When using LC or copper tape shield cables, the range may be extended upwards.
- 3) The lower case "e" in the part numbers 15 thru 28kV indicates the splices have a built-in electrode. This eliminates the need to apply high permittivity mastic over the connector. The three larger (H, IP, I and J) 35kV splices are supplied with high permittivity mastic.
- 4) Prysmian Elasppeed splices meet IEEE 404 specifications.

Contact your Prysmian sales representative for more information such as data on size transition limits or for conductor sizes not shown.

Splice Kit Adder Options

Prysmian Group can supply your requested splice kit with a conductor connector upon request. Please contact your local Prysmian sales representative for assistance in selecting the best shear bolt or compression connector option to be included in splice kit offering.



Prysmian

4 Tessenere Drive, Highland Heights, KY 41076
na.prysmian.com
ACS-DS-0003-1024

Shearbolt® Connectors

Fast, Reliable Medium Voltage Connections



RATINGS

- ANSI C119.4-2004
- ANSI Class 2 (40% RBS)
- Dual-Rated (AL/CU)

ELECTRICAL PROPERTY

- Current Cycle Test - Class A @ 284°F (140°C) Conductor
- Mechanical Pullout Test -Class 2

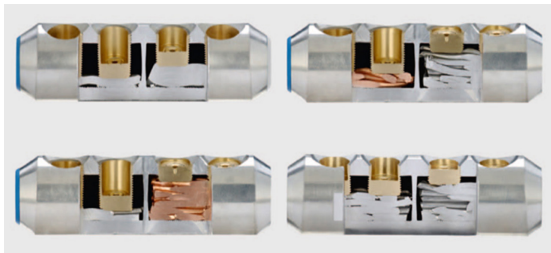

STEPLESS TECHNOLOGY

The stepless Shearbolt has no pre-set shear points in the threads and makes use of the maximum number of bolt threads possible to apply a compressive force to the conductor. The stepless technology ensures that the bolt will shear off below the surface of the connector, eliminating the need for filing sharp metal edges.

HEX KEY BOLTS

No special tools are required to install the connector since the shearbolts are equipped with hex key fittings. Only 5 mm, 6 mm, or 8 mm standard hex keys are needed.

OVERVIEW

Prysmian Mechanical Shearbolt Connectors are designed to cover a wide range of conductor sizes from 6 AWG to 1500 kcmil. Individual sizes cover ranges from 6 AWG-3/0, 2 AWG-250 kcmil, 1/0 AWG -500 kcmil, 350-750 kcmil, 500-1000 kcmil and 750-1250 kcmil. The unique stepless Shearbolt design has no predetermined breaking points in the connector thread. Bolts always break flush with the surface of the connector body.

The design provides excellent performance and features not found in other mechanical connectors. They meet ANSI C119.4 and withstand the 40% pull out force (ANSI Class 2) required by IEEE-404. No compression dies or mechanical crimp tooling are required for installation. Following cable preparation, simply slide the connector over the conductor and tighten the bolts until they shear off.

Prysmian Mechanical Shearbolt Connectors are dual-rated (AL/CU) and tin-plated to resist corrosion. Compatible with the full line of Prysmian Elasppeed™ cold-applied splice kits, they offer the best medium voltage cable splicing solution.

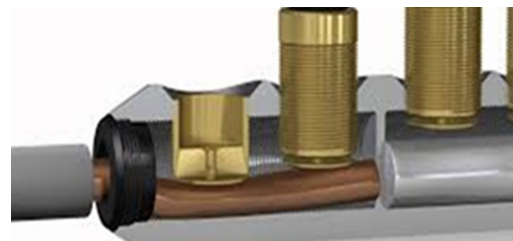

FRICTION DISC

As the bolt is tightened, the friction disc at the base of the bolt makes contact with the conductor and no longer rotates. The bolt rotates freely above the friction disc without putting torque on the conductor. This allows the shearbolt to apply the optimum amount of contact force without damaging even finely stranded conductors.

COMPATIBILITY

Prysmian shearbolt connectors are designed to be compatible with Prysmian Elasppeed™ cold-applied splice kits. Two superior technologies provide for a quick and easy installation that saves time and cost over traditional methods.

Shearbolt® Connectors

Fast, Reliable Medium Voltage Connections



FEATURE	ADVANTAGE	BENEFIT
Wide application range	Reduced number of connectors to accommodate cable sizes from #6 to 1,500 kcmil	Reduces accidental use of the wrong connector
Each connector covers multiple conductor sizes	Range-taking in each connector	Reduced inventory
Step-less shearhead bolts	Installs with simple ratchet-type socket wrench or cordless impact wrench	Eliminates need for heavy crimp tooling and special dies
Bolts are continuous shearing	Bolts shear at or below the connector surface	No time-consuming filing is needed
Friction disk stops rotating upon conductor contact	Provides increased contact force	Will not damage fine stranded conductors
Compact, smooth body design	Compatible with Prysmian Cold Shrink Elaseed™ Splices	An engineered system providing years of trouble-free performance
Torque-controlled shearhead bolts	Sheared head gives positive indication of correct installation	Provides positive feedback that the connection is fully tightened
Heavy-duty design	Connector bodies are made of high strength, tin-plated aluminum alloy	Provides long service life under normal operation conditions with reserve capacity.
Centering rings for small diameter conductors	Minimizes voltage stresses at transition from connector body to cable insulation.	No separate metal inserts required – less parts to handle.
Factory filled oxide-inhibiting compound	Abrades and penetrates the conductor oxides	Generates low initial contact resistance and long term reliability
Knurled Inner bore	Unique profile breaks through oxides and grips conductor strands	Generates low contact resistance & increases mechanical pullout strength. Meets Class 2, 40% RBS of the conductor.
Solid center stop	Mechanical barrier is impervious to oil	Accommodates transition applications from polymeric to PILC cable
Dual-rated	Designed and tested for use on both aluminum and copper conductors	Ideal for aluminum to copper conductor transitions
No crimping required	No crimping dies, crimp tooling or calibration of crimp tool required	Easy installation - particularly in confined spaces
Transitions between conductor sizes	One connector can easily accommodate size transitions	Eliminates use of adapters that can impede electrical conductivity

Shearbolt® Connectors

Fast, Reliable Medium Voltage Connections



Shear Bolt Connectors

Catalog Description	Part Number	Connector Range AWG / kcmil	Connector Length w/Centering Rings Inches (mm)	Connector O.D. Inches (mm)	Hex Key Size	Number of Bolts
6-3/0-ALSB	CUS53825	#6 to 3/0	2.95 (75)	.95 (24)	5 mm	2
2-250-ALSB	CUS53821	#2 to 250	4.41 (112)	1.10 (28)	5 mm	4
1/0-500-ALSB	CUS53783	1/0 to 500	5.12 (130)	1.38 (35)	6 mm	4
350-750-ALSB	CUS53826	350 to 750	6.93 (176)	1.65 (42)	8 mm	6
500-1000-ALSB	CUS53919	500 to 1000	7.83 (199)	2.05 (52)	8 mm	6
750-1250-ALSB	CUS53828	750 to 1250	10.15 (258)	2.10 (53)	8 mm	8
1250-1500-ALSB	CUS54040	1250 to 1500	9.69 (246)	2.36 (60)	8 mm	8

Two Hole Shear Bolt Lugs

Catalog Description	Part Number	Connector Range AWG / kcmil	Connector Length w/Centering Rings Inches (mm)	Connector O.D. Inches (mm)	Hex Key Size	Number of Bolts
7-3/0-ALSB2	CUS53822	#7 to 3/0	5.16 (131)	0.94 (24)	5 mm	2
2-250-ALSB2	CUS53939	#2 to 250	5.98 (152)	1.10 (28)	5 mm	2
4/0-500-ALSB2	CUS53829	4/0 to 450/500	6.32 (161)	1.38 (35)	6 mm	2
500-750-ALSB2	CUS53942	500 to 750	7.54 (192)	1.65 (42)	8 mm	3
750-1000-ALSB2	CUS53943	750 to 1000	8.37 (213)	2.05 (52)	8 mm	3
1000-1250-ALSB2	CUS53945	1000 to 1250	8.37 (213)	2.05 (52)	8 mm	3
1250-1500-ALSB2	CUS53913	1250 to 1500	9.09 (231)	2.36 (60)	8 mm	4

Note: Applicable only to 500 kcmil compact conductor designs.

Shear Bolt Pin Terminal

Catalog Description	Part Number	Connector Range AWG / kcmil	Connector Length w/Centering Rings Inches (mm)	Connector O.D. Inches (mm)	Hex Key Size	Number of Bolts
#2-4/0-ALSBPIN	CUS54041	#2 to 4/0	9.51 (241.5)	0.94 (24)	5 mm	1

600A/900A Deadbreak Series

(15kV/25kV)



OVERVIEW

The 600/900 amp Deadbreak Elbow and accessories offer an easy and reliable method of terminating and splicing main feeder circuits. The Deadbreak Elbow is a fully shielded, molded rubber connector.

The Deadbreak Elbow is designed to terminate power cables with copper or aluminum conductors ranging in sizes from #2 AWG to 1250 kcm. It may be installed on any 600-Amp rated (aluminum) apparatus bushing that meets IEEE Standard 386 latest revision for Separable Insulated Connectors. Cable adapters accommodate power cable insulation diameters from 0.530 to 1.935 inches.

If all-copper components are used, the Deadbreak Elbow assembly has a 900A rating. Otherwise, the assembly is rated for 600A.

INTERCHANGEABILITY

The Deadbreak Elbow has been designed and tested to meet the requirement of IEEE Standard 386. Conformance to this industry standard ensures mechanical and electrical interchangeability with other products of manufacturers that are also in conformance with the standard.

Electrical Ratings MEETS OR EXCEEDS IEEE STANDARD 386 – Latest Revision

Continuous Current Rating (Aluminum Components)	600 amps
Voltage Class	25kV
Max Phase to Ground Voltage – Operating Voltage	15.2kV
Max Phase to Phase Voltage	26.3kV
Basic Impulse Level (1.2x50µs)	125kV
Corona Extinction (3pC)	19kV
AC Withstand Voltage (1 min.)	40kV
DC Withstand Voltage (15 min.)	78kV
24 Hour Overload	1,000 Amps rms
Short-Circuit Time Rating	25,000 Amps rms symmetrical for 0.17 sec. 10,000 Amps rms symmetrical for 3.00 sec.
Corona (3pC)	19kV
AC Withstand (1 min.)	40kV

600A/900A Deadbreak Series (15kV/25kV)



FEATURES

1. Cable Adapter - Molded of peroxide cured EPDM rubber. Designed to accept specified cable insulation diameters. Radial pressure exerted on the cable insulation by the cable adapter precludes the presence of corona causing air voids along the cable adapter and cable insulation interface. The outside diameter of the cable adapter is constant for all cable adapter sizes.

2. Compression Connector - Aluminum (600 amp). Sized for the specific conductor size. Crimped with standard tools and dies.

3. Test Point - Designed to allow voltage indication when readout is made with suitable high impedance measuring devices. Elbows are available with and without this feature.

4. Insulating Plug Cap - Molded of conductive peroxide cured EPDM rubber providing a continuous outer shield for the elbow. Snaps tightly over the test point and onto the elbow body.

5. Epoxy Insulating Plug - Hex nut located on top of the insulating plug is used to tighten the plug when assembling the elbow.

6. Hex Nut - One-inch hex head is used to tighten the connection. Can also be used as a capacitive test point. See #3 above.

7. Molded External Shield - Conductive, abrasion-resistant shield of peroxide cured EPDM rubber. Provides ground shield continuity and meets the requirements of IEEE Standard 592.

8. Drain Wire Tab - Designed to accept a single #14 AWG copper wire that can be inserted into the eye. Provides a static ground to ensure deadfront construction.

9. Stress Relief Cone - Designed into the cable adapter providing electrical stress relief at the point of terminating the power cable shield. Controls the electrical field entering the elbow.

10. EPDM Insulation - Peroxide cured EPDM rubber.



600A/900A Deadbreak Series (15kV/25kV)



Deadbreak T-Bodies

Part No.	Cable Range Insulation Diameter (In)	5kV 100	5kV 133% / 8kV 100%	8kV 133%	15kV 100%	15kV 133%	25kV 100%	25kV 133%
1525DB_E	0.530 - 0.675	#1 AWG - 2/0 AWG	#2 AWG - 2/0 AWG	#1 AWG - 1/0 AWG	#2 AWG	—	—	—
1525DB_F	0.640 - 0.840	3/0 AWG - 350 kcm	2/0 AWG - 250 kcm	1/0 AWG - 4/0 AWG	#2 AWG - 3/0 AWG	#2 AWG - 1/0 AWG	—	—
1525DB_G	0.760 - 0.950	350 kcm - 500 kcm	4/0 AWG - 350 kcm	4/0 AWG - 250 kcm	2/0 AWG - 250 kcm	#1 AWG - 3/0 AWG	#1 AWG - 2/0 AWG	—
1525DB_H	0.850 - 1.050	500 kcm	350 kcm - 500 kcm	250 kcm - 350 kcm	4/0 AWG - 350 kcm	2/0 AWG - 250 kcm	1/0 AWG - 4/0 AWG	#1 AWG - 1/0 AWG
1525DB_J	0.980 - 1.180	750 kcm	500 kcm	500 kcm	350 kcm - 500 kcm	250 kcm - 350 kcm	4/0 AWG - 250 kcm	1/0 AWG - 4/0 AWG
1525DB_K	1.090 - 1.310	750 kcm	750 kcm	750 kcm	500 kcm	350 kcm - 500 kcm	350 kcm - 500 kcm	3/0 AWG - 250 kcm
1525DB_L	1.180 - 1.465	750 kcm - 1000 kcm	750 kcm - 1000 kcm	750 kcm - 1000 kcm	750 kcm	500 kcm - 750 kcm	500 kcm	250 kcm - 500 kcm
1525DB_M	1.370 - 1.630	—	—	—	1000 kcm - 1250 kcm	1000 kcm	750 kcm	500 kcm - 750 kcm
1525DB_N	1.515 - 1.780	—	—	—	1250 kcm	1000 kcm - 1250 kcm	1000 kcm	750 kcm - 1000 kcm
1525DB_P	1.725 - 1.935	—	—	—	—	—	1250 kcm	1000 kcm - 1250 kcm

NOTE: Cable sizes are conservative estimates based on compact cable design. To properly size a kit to cable, reference the **Insulation Diameter** ranges

Note: Replace "_" with "CN" for Concentric Neutral Cable

Example: For a 1/0 AWG Compact 15kV 100% Cable with CN use body 1525DBCNF-600DB23

Note: Replace "_" with "CTS" for Copper Tape Shield or LC Shield Cables

Example: For a 500 kcm 25kV Stranded 133% Cable with LC or Copper Tape Shield use body 1525LBCTSB-600DB33

Remember to add the required lug to the body part number per the Connector Table.

Deadbreak Shear Bolt Connectors

Description	Part No.	Nominal Conductor Range*		Compression Lug Code Equiv.		# of Bolts	Hex Key Size
		Min	Max	Min	Max		
Shear Bolt Lug #3 - 300	CUS600DBSB1	#3	300	6	14	2	5 mm
Shear Bolt Lug 1/0 - 450	CUS600DBSB2	1/0	450 Strd/500 Cmpt	9	17	2	6 mm
Shear Bolt Lug 4/0 - 600	CUS600DBSB3	3/0	600	11	20	2	8 mm
Shear Bolt Lug 350 - 750	CUS600DBSB4	300 Cmpt / 350 Cmpt	750 Strd/900 Cmpt	14	23	3	8 mm
Shear Bolt Lug 600 - 1250	CUS600DBSB5	600	1250	20	29	3	8 mm
Shear Bolt Lug 1500	CUS600DBSB6**	1500		30		4	8 mm

Shear bolt connectors can be used for 600A and 900A applications.

* Unless otherwise noted conductor size listed is stranded/compressed/compact.

** For use on 35kV Deadbreak Series. For other applications contact the factory.



Prysmian

4 Tesseneer Drive, Highland Heights, KY 41076
na.prysmian.com
ACS-DS-0002-0624

600A/900A Deadbreak Series

(15kV/25kV)



Deadbreak Compression Connectors

Part No.	Stranded / Compressed	Compact / Solid	Part No.	Stranded / Compressed	Compact / Solid
600DB21	#3	#2	600DB32	450	500/550
600DB22	#2	#1	600DB33	500	600
600DB23	#1	1/0	600DB34	550	650
600DB24	1/0	2/0	600DB35	600	700
600DB25	2/0	3/0	600DB36	650	750
600DB26	3/0	4/0	600DB38	700/750	900
600DB27	4/0	250	600DB39	800	—
600DB28	250	300	600DB40	900	1000
600DB29	300	350	600DB41	1000	—
600DB30	350	400	600DB44	1250	—
600DB31	400	450			

600A/900A Deadbreak Series (35kV)



OVERVIEW

The 600/900 amp Deadbreak Elbow and accessories offer an easy and reliable method of terminating and splicing main feeder circuits. The Deadbreak Elbow is a fully shielded, molded rubber connector.

The Deadbreak Elbow is designed to terminate power cables with copper or aluminum conductors ranging in sizes from #2 AWG to 1250 kcm. It may be installed on any 600-Amp rated (aluminum) apparatus bushing that meets IEEE Standard 386 latest revision for Separable Insulated Connectors. Cable adapters accommodate power cable insulation diameters from 0.530 to 1.935 inches.

If all-copper components are used, the Deadbreak Elbow assembly has a 900A rating. Otherwise, the assembly is rated for 600A.

INTERCHANGEABILITY

The Deadbreak Elbow has been designed and tested to meet the requirement of IEEE Standard 386. Conformance to this industry standard ensures mechanical and electrical interchangeability with other products of manufacturers that are also in conformance with the standard.

Electrical Ratings MEETS OR EXCEEDS IEEE STANDARD 386 – Latest Revision

Continuous Current Rating (Aluminum Components)	600 amps
Voltage Class	35kV
Max Phase to Ground Voltage – Operating Voltage	21.1kV
Basic Impulse Level (1.2x50µs)	200kV
Corona Extinction (3pC)	26kV
AC Withstand Voltage (1 min.)	50kV
4 Hour Overload	900 Amps
Short-Circuit Time Rating	25,000 Amps rms symmetrical for 0.17 sec. 10,000 Amps rms symmetrical for 3.00 sec.

600A/900A Deadbreak Series (35kV)



FEATURES

- 1. Cable Adapter** - Molded of peroxide cured EPDM rubber. Designed to accept specified cable insulation diameters. Radial pressure exerted on the cable insulation by the cable adapter precludes the presence of corona causing air voids along the cable adapter and cable insulation interface. The outside diameter of the cable adapter is constant for all cable adapter sizes.
- 2. Compression Connector** - Aluminum (600 amp). Sized for the specific conductor size. Crimped with standard tools and dies.
- 3. Test Point** - Designed to allow voltage indication when readout is made with suitable high impedance measuring devices. Elbows are available with and without this feature.
- 4. Insulating Plug Cap** - Molded of conductive peroxide cured EPDM rubber providing a continuous outer shield for the elbow. Snaps tightly over the test point and onto the elbow body.
- 5. Epoxy Insulating Plug** - Hex nut located on top of the insulating plug is used to tighten the plug when assembling the elbow.
- 6. Hex Nut** - One-inch hex head is used to tighten the connection. Can also be used as a capacitive test point. See #3 above.
- 7. Molded External Shield** - Conductive, abrasion-resistant shield of peroxide cured EPDM rubber. Provides ground shield continuity and meets the requirements of IEEE Standard 592.
- 8. Drain Wire Tab** - Designed to accept a single #14 AWG copper wire that can be inserted into the eye. Provides a static ground to ensure deadfront construction.
- 9. Stress Relief Cone** - Designed into the cable adapter providing electrical stress relief at the point of terminating the power cable shield. Controls the electrical field entering the elbow.
- 10. EPDM Insulation** - Peroxide cured EPDM rubber.

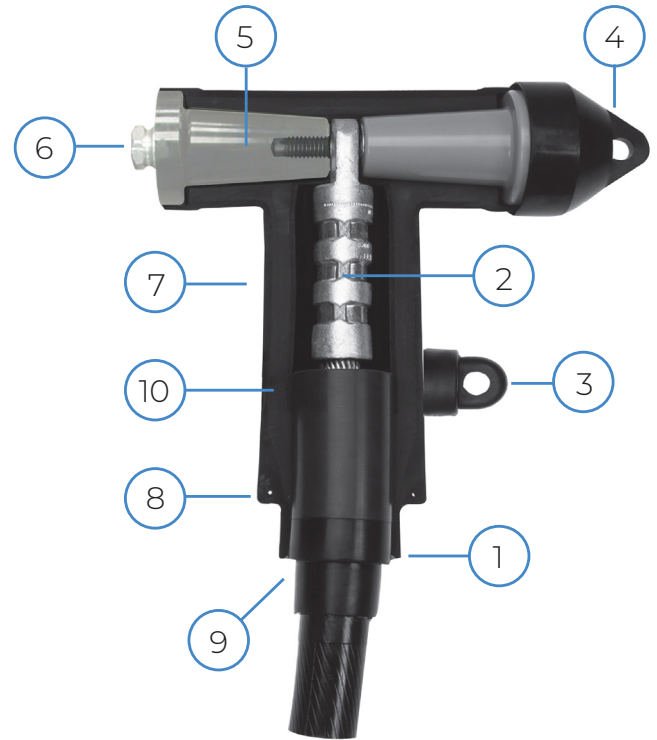

600A/900A Deadbreak Series (35kV)



Deadbreak T-Bodies

Part Number	Insulation Diameter (In)	35kV 100%	35kV 133%
35DB__H	0.850 – 1.050	—	—
35DB__J	0.980 – 1.115	1/0 AWG	—
35DB__K	1.090 – 1.310	3/0 – 4/0 AWG	2 – 2/0 AWG
35DB__L	1.180 – 1.465	250 – 350 kcm	2/0 AWG – 250 kcm
35DB__M	1.370 – 1.630	500 – 600 kcm	350 kcm
35DB__N	1.515 – 1.780	600 – 750 kcm	500 – 600 kcm
35DB__P	1.725 – 1.935	1000 kcm	750 kcm
35DB__Q	1.900 – 2.120	1250 – 1500 kcm	1000 – 1250 kcm

NOTE: Cable sizes are conservative estimates based on compact cable design. To properly size a kit to cable, reference the Insulation Diameter ranges

NOTE: Replace “__” with “CN” for Concentric Neutral Cable

Example: For a 1/0 AWG Compact 15kV 100% Cable with CN use body 1525DBCNF-600DB23

NOTE: Replace “__” with “CTS” for Copper Tape Shield or LC Shield Cables

Example: For a 500 kcm 25kV Stranded 133% Cable with LC or Copper Tape Shield use body 1525LBCTSB-600DB33

Remember to add the required lug to the body part number per the Connector Table.

Example: 35DBCTSN-600DB35 for 500mcm 100% cable

Deadbreak Shear Bolt Connectors

Description	Part No.	Nominal Conductor Range*		Compression Lug Code Equiv.		# of Bolts	Hex Key Size
		Min	Max	Min	Max		
Shear Bolt Lug #3 - 300	CUS600DBSB1	#3	300	6	14	2	5 mm
Shear Bolt Lug 1/0 - 450	CUS600DBSB2	1/0	450 Strd/500 Cmpt	9	17	2	6 mm
Shear Bolt Lug 4/0 - 600	CUS600DBSB3	3/0	600	11	20	2	8 mm
Shear Bolt Lug 350 - 750	CUS600DBSB4	300 Cmpr /350 Cmpt	750 Strd/900 Cmpt	14	23	3	8 mm
Shear Bolt Lug 600 - 1250	CUS600DBSB5	600	1250	20	29	3	8 mm
Shear Bolt Lug 1500	CUS600DBSB6**	1500		30		4	8 mm

Shear bolt connectors can be used for 600A and 900A applications.

* Unless otherwise noted conductor size listed is stranded/compressed/compact.

** For use on 35kV Deadbreak Series. For other applications contact the factory.



600A/900A Deadbreak Series (35kV)



Deadbreak Compression Connectors

Part No.	Stranded / Compressed	Compact / Solid	Part No.	Stranded / Compressed	Compact / Solid
600DB21	#3	#2	600DB32	450	500/550
600DB22	#2	#1	600DB33	500	600
600DB23	#1	1/0	600DB34	550	650
600DB24	1/0	2/0	600DB35	600	700
600DB25	2/0	3/0	600DB36	650	750
600DB26	3/0	4/0	600DB38	700/750	900
600DB27	4/0	250	600DB39	800	—
600DB28	250	300	600DB40	900	1000
600DB29	300	350	600DB41	1000	—
600DB30	350	400	600DB44	1250	—
600DB31	400	450			

Cable Preparation Tools

MV Accessories



OVERVIEW

Prysmian is proud to offer some of the industry's finest cable preparation tools for use on Low and Medium Voltage cables. Long-term product performance and grid reliability depends on the correct installation of cable accessories. Using cable preparation tools specifically designed to assist in the installation of Low and Medium Voltage Accessories can help to mitigate the risks of failures due to improper cable preparation procedures.



PG Series

The ALROC PG Series plier is designed for removing the outer sheath on medium voltage cable. It enables the user to make a circular and longitudinal cut to remove the cable's outer sheath.

PG SERIES PRODUCT INFORMATION

Part Number	Diameter Range INCHES (mm)	Circular Blade Depth INCHES (mm)	Longitudinal Blade Depth INCHES (mm)
PG2-MV/C079L079	0.80 – 1.40 (20 – 36)	0.079 (2.0)	0.079 (2.0)
PG3-MV/C039L070	1.00 – 2.00 (25 – 51)	0.039 (1.0)	0.070 (1.8)
PG3-MV/C110L130	1.00 – 2.00 (25 – 51)	0.110 (2.8)	0.130 (3.3)
PG4-MV/C110L130	1.85 – 3.00 (47 – 76)	0.110 (2.8)	0.130 (3.3)
PG5-MV/C138L138	2.55 – 3.70 (65 – 94)	0.138 (3.5)	0.138 (3.5)
PG6-MV/C138L138	3.14 – 4.90 (80 – 124)	0.138 (3.5)	0.138 (3.5)

PG SERIES REPLACEMENT CIRCULAR BLADES

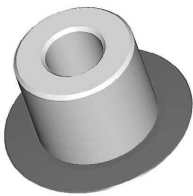

Part Number	Circular Blade Depth INCHES (mm)	Quantity
C039	0.039 (1.0)	4 Blades / Tool
C079	0.079 (2.0)	
C110	0.110 (2.8)	
C138	0.138 (3.5)	

PG SERIES REPLACEMENT LONGITUDINAL BLADES



Part Number	Circular Blade Depth INCHES (mm)	Quantity
L070	0.070 (1.8)	1 Blade / Tool
L079	0.079 (2.0)	
L130	0.130 (3.3)	
L138	0.138 (3.5)	



Prysmian

4 Tesseneer Drive, Highland Heights, KY 41076
+1-859-572-8000 / na.prysmian.com
ACS-DS-0019-0924

Cable Preparation Tools

MV Accessories



PF3

The ALROC PF3 plier was designed specifically for use on longitudinally corrugated (LC) shielded cable allowing the user to make a circular cut on the corrugated shield prior to its removal. The grooves on the bushing allow the user to make a score on the LC shield without touching the semiconducting layer underneath.

PF3 PRODUCT INFORMATION

Part Number	Diameter Range INCHES (mm)	Circular Cutting Thickness Capacity INCHES (mm)
PF3/024	1.024 – 2.047 (26 – 52)	0.024 (0.6)



MVS

The ALROC MVS Stop is designed to be a tool stop for associated tools on 1 and 3 core cables. The tool can be tightened around the cable to ensure clean and straight cutbacks.

MVS PRODUCT INFORMATION

Part Number	Diameter Range INCHES (mm)
MVS	0.709 – 2.362 (18 – 60)

ASSOCIATED TOOLS:

- CWB/18-60-FEP
- LHM1R 30/45
- LHM2R 30/60
- MF3/60-SRC-USA

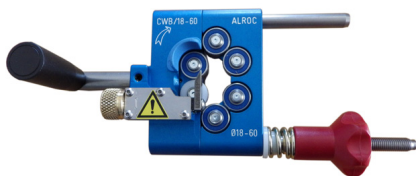

CWB/18-60

The ALROC CWB/18-60 tool is designed for use on Medium Voltage Cable to remove the bonded semiconductor with a chamfer on the transition, leaving a smooth finish over the insulation. The tool allows the user to fine tune the cut depth and an adjustable semiconductor cutback.

CWB/18-60 PRODUCT INFORMATION

Part Number	Diameter Range INCHES (mm)	Tool Capacity		
		Thickness Capacity INCHES (mm)	Angle of Chamfer	Semiconductor Cutback Stops INCHES (mm)
CWB/18-60-FEP	0.709 – 2.362 (18 – 60)	0.071 (1.8)	13°	0.984 - 1.181 - 1.575 (25 - 30 - 40)

CWB/18-60 REPLACEMENT BLADE

Part Number	Thickness Capacity INCHES (mm)	Angle of Chamfer
LCWB-FEP	0.071 (1.8)	13°

Cable Preparation Tools

MV Accessories



LHM Series

The ALROC LHM series is designed to assist with removing peelable semiconductor from the cable insulation by hand. The blade is adjustable, and the tool comes with an adjustable stop for common cutback dimensions.

LHM SERIES PRODUCT INFORMATION

Part Number	Diameter Range INCHES (mm)	Semiconductor Cutback Stops INCHES (mm)
LHM1R 30/45	0.551 – 1.575 (14 – 40)	1.181 – 1.575 (30 – 40)
LHM2R 30/60	1.496 – 2.362 (38 – 60)	1.181 – 1.575 – 1.772 – 2.165 – 2.362 (30 – 40 – 45 – 55 – 60)

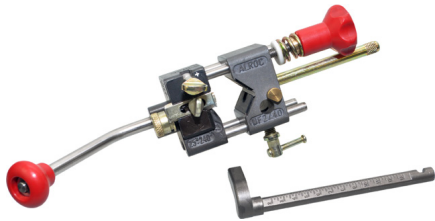

MF2 Series

The ALROC MF2 Series multifunction tool allows the user to remove the outer sheath (PE-PVC-PR) as well as set the length and remove cable insulation with a straight and neat cut.

MF2 SERIES PRODUCT INFORMATION

Part Number	Diameter Range INCHES (mm)	Thickness Capacity INCHES (mm)
MF2/40-S-USA	0.630 – 1.575 (16 – 40)	0.433 (11)
MF2/60-S-USA	0.630 – 2.283 (16 – 58)	0.433 (11)

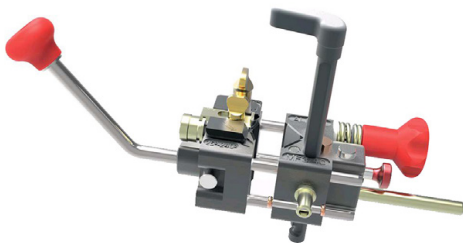

MF3 Series

The ALROC MF3 Series multifunction tool allows the user to remove the outer sheath (PE-PVC-PR), as well as set the length and remove cable insulation with a straight and neat cut. The SCH stylus insert enables the user to make a chamfer on the extremity of the primary insulation.

MF3 SERIES PRODUCT INFORMATION

Part Number	Diameter Range INCHES (mm)	Tool Capacity INCHES (mm)		Stylus Included
		Peelable Semicon Thickness Capacity	Insulation Thickness Capacity	
MF3/60-SCH-USA	0.630 – 2.283 (16 – 58)	0.015 – 0.059 (0.4 – 1.5)	0.433 (11)	Chamfered

Cable Preparation Tools

MV Accessories

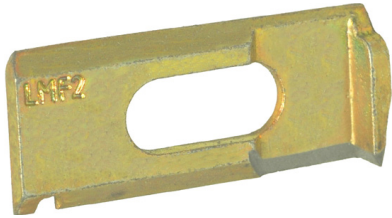

LMF2

Replacement Blade for thick outer sheath and insulation for use with the ALROC MF2 and MF3 Series.

LMF2 PRODUCT INFORMATION

Part Number	Cutting Depth INCHES (mm)
LMF2	0.433 (11)



KIT-MF PADS

Replacement wear pad kit for use with ALROC MF2 and MF3 Series tools. 5 Complete sets included in each kit.

KIT-MF PRODUCT INFORMATION

Part Number	Sets Per Kit
KIT-MF	5



DSP

The ALROC DSP tool removes and catches the peelable semiconductor at the cable end allowing the user to remove it by hand.

DSP PRODUCT INFORMATION

Part Number	Diameter Range INCHES (mm)	Type of Semiconductor
DSP	0.394 – 3.150 (10 – 80)	Smooth or ribbed peelable



EVP

The ALROC EVP tool enables the user to flare and spread the lead sheath or the tabs made from the lead sheath.

EVP PRODUCT INFORMATION

Part Number	Diameter Range INCHES (mm)
EVP	0.591 – 9.449 (15 – 240)



EV 630

The ALROC EV 630 enables the user to spread the tabs of the PVC outer sheath with glued aluminum screen to ease the positioning of the screen ring under the outer sheath.

EV 360 PRODUCT INFORMATION

Part Number	Diameter Range INCHES (mm)
EV 630	1.575 – 2.362 (40 – 60)

Cable Preparation Tools

MV Accessories



Pfisterer SICON Holding Tools

The Pfisterer SICON Holding Tools are designed to provide extra leverage when installing the SICON shear bolt connector. They can be used with a handheld socket or a battery-operated impact wrench. The coating on the holding tool is rated at 1kV for low voltage applications and is optimal when installation requires a single person.

PFISTERER SICON HOLDING TOOL PRODUCT INFORMATION

Part Number	Diameter Range INCHES (mm)	Length INCHES (mm)
331 903 001	0.55 – 1.25 (14 – 32)	11.5 (295)
331 903 002	1.20 – 2.00 (25 – 50)	12.5 (315.5)

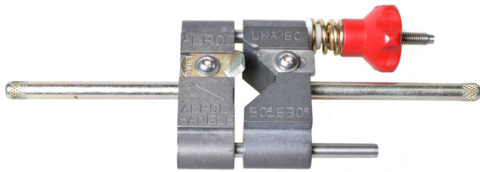

LHA/60

The ALROC LHA/60 tool enables the user to realize a chamfer of 30° at the extremity of the insulation of medium voltage cables.

LHA/60 PRODUCT INFORMATION

Part Number	Diameter Range INCHES (mm)	Chamfer Angle
LHA/60	0.787 – 2.165 (20 – 55)	30°



WIRE BRUSH

Prysmian offers Stainless-Steel Wire Brushes with a wood handle. Aluminum Conductors exposed to oxygen will begin to develop a thin, hard film of aluminum oxide leading to corrosion. Wire brushes are recommended to clean aluminum oxide from the conductor during cable preparation prior to installing the connector.

SS-BRUSH PRODUCT INFORMATION

Part Number	Handle Length INCHES (mm)	Handle	Handle	QTY/Case
SS-BRUSH	0.787 – 2.165 (20 – 55)	Wood	Stainless Steel	5



Cable Preparation Tools

MV Accessories



ROTOGRAT

The ALROC ROTTOGRATT tool allows for medium voltage cables sheath abrasion to obtain a good adherence of medium voltage accessories and guarantees junction equipment.

ROTOGRATT PRODUCT INFORMATION

Part Number	Diameter Range INCHES (mm)	Abrasion Length INCHES (mm)
ROTOGRATT RTT2	0.787 – 2.047 (20 – 52)	1.968 (50)

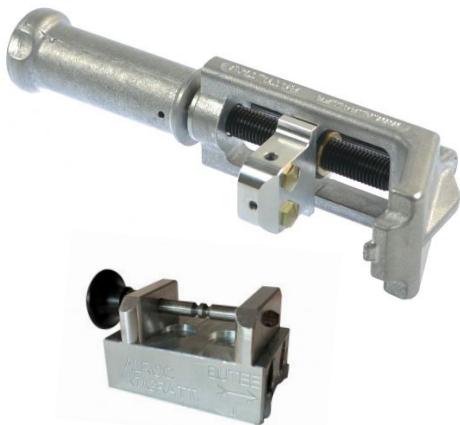

ROTO-TMG

The ALROC ROTO-TMG tool is an adjustable multifunction tool that holds fittings and lugs mechanically tight and to be used when stopping and sheathing. When combined with the ALROC K7/GRATT enables the user to abrade the outer sheath of the cable to ensure a good sealing of the cable accessory.

ROTO-TMG PRODUCT INFORMATION

Part Number	Diameter Range INCHES (mm)	Abrasion Length INCHES (mm)
ROTO-TMG w/ K7/GRATT	0.630 – 2.362 (16 – 60)	1.969 (50)

K7/GRATT Attachment



Journeyman™ T-Handle Hex Key

The Journeyman™ T-Handle Hex Key tool is used for installing Deadbreak T body/ Loadbreak Components.

JOURNEYMAN T-HANDLE HEX KEY PRODUCT INFORMATION

Part Number	Hex Key Length INCHES (mm)	Length INCHES (mm)
516HEXTW	0.31 (7.938)	9 (228.6)



Prysmian

4 Tesseneer Drive, Highland Heights, KY 41076
+1-859-572-8000 / na.prysmian.com
ACS-DS-0019-0924



na.prysmian.com

ACS-0007-1124

Follow us

