

35kV 600/900A Deadbreak



600/900A Deadbreak Elbow



DESCRIPTION

The 600/900 Amp Deadbreak Elbow and accessories offer an easy and reliable method of terminating and splicing main feeder circuits. The Deadbreak Elbow also known as a “T Body”, is a fully shielded, molded EPDM rubber connector utilizing a high-torque, bolted connection making it ideal for highly loaded circuits with high fault currents. Our Deadbreak Elbows are designed for use on solid dielectric cable (XLPE or EPR) with semi-conductive and neutral shielding. The accessory can be installed on cable with or without an outer jacket.

900A RATING

The Deadbreak Elbow can be rated for 900A continuous current when used with a copper top compression connector or shear bolt, copper insulating plug, copper stud, and copper bushing or junction.



INTERCHANGEABILITY

The Deadbreak Elbow has been designed and tested to meet the requirement of IEEE Standard 386, Interface 13. Conformance to this industry standard ensures mechanical and electrical interchangeability with other products of manufacturers that are also in conformance with the standard.



SPECIFICATIONS AND RATINGS:

For Reference, IEEE 386 ratings are provided below.

IEEE 386 – Industry Minimum Requirements	
Voltage Ratings	
Voltage Class, Phase to Phase	35kV
Maximum Operating Voltage – Phase to Ground	21.1kV
Corona Voltage Level – Partial Discharge Extinction Voltage	35kV 
AC Withstand – 1 minute	81kV 
Impulse Withstand Voltage - BIL	200kV 
Continuous Current Ratings	
Aluminum Components Utilized	600A
Copper Components Utilized	900A
Short Time Current Ratings	
Aluminum Components Utilized	25kA, 10cycles and 10kA, 3sec.
Copper Components Utilized	40kA, 10cycles and 10kA, 3sec.

 Exceeds IEEE 386 requirement

FEATURES AND BENEFITS

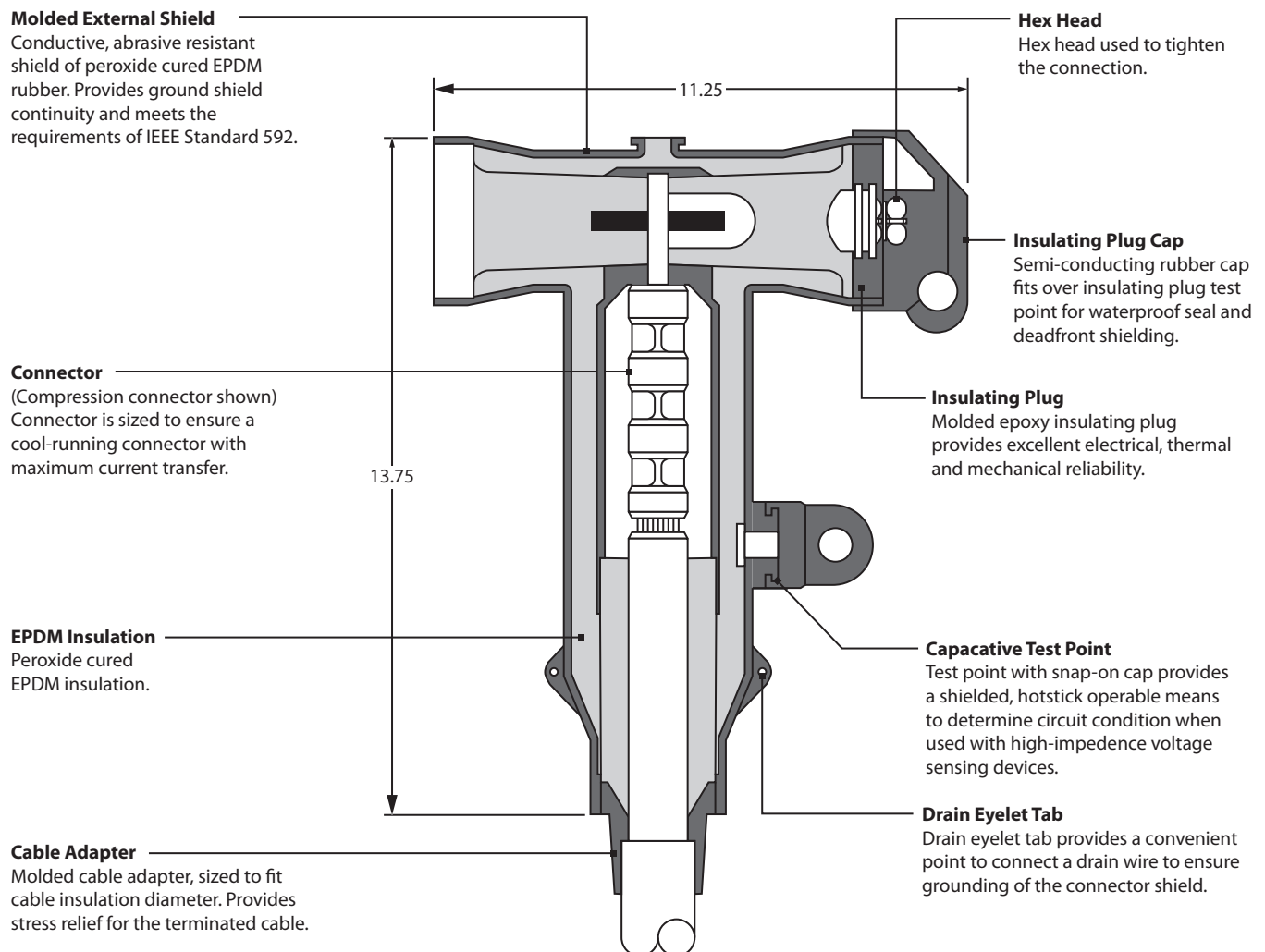

Dimensions are for reference only.

APPLICATIONS

- Outdoor
- Vaults
- Enclosures
- Direct Bury
- Submersible

600/900A Deadbreak Elbow



KIT SELECTION

Use the tables (T#) below to assemble the full catalog ID for the kit needed.

NOTE: Product Series = DBT (Deadbreak T Body with Test Point)

NOTE: Voltage Class = 35 (35kV Deadbreak T Body)

EXAMPLE: DBT635M-E-S4100-ALSBL2-1P

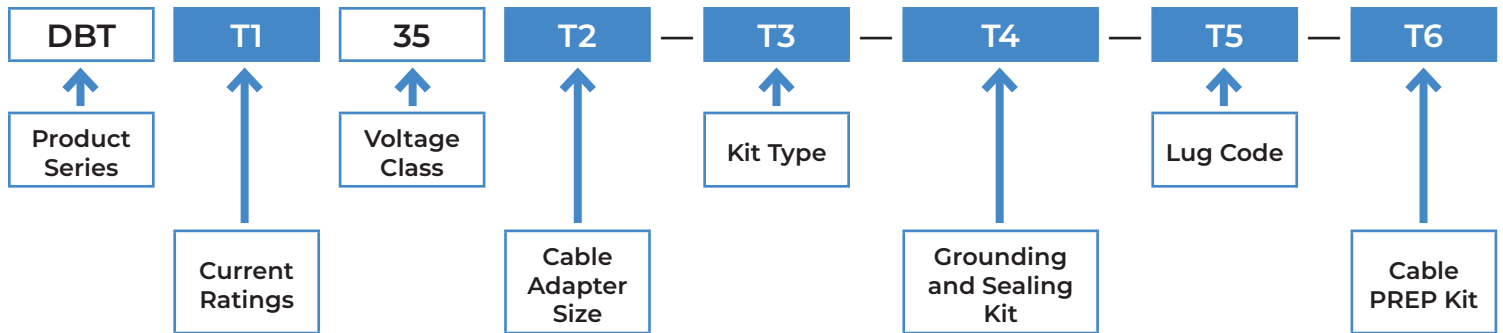

T1 – Current Ratings

Catalog ID	Description
6	600A (Aluminum Components)
9	900A (Copper Components)

T2 – Cable Adapter Size

Catalog ID	Insulation Range INCHES	35kV 100%	35kV 133%
NA	No Adapter	-	-
H	0.85 – 1.05	-	1-4/0
J	0.98 – 1.115	1/0	3/0-300
K	1.09 – 1.31	3/0-4/0	250-450
L	1.18 – 1.465	250-350	350-550
M	1.37 – 1.63	500-600	500-750
N	1.515 – 1.78	600-750	600-900
P	1.725 – 1.935	1000	800-1000
Q	1.90 – 2.12	1250-1500	1250
R	2.00 – 2.235	1500	1250-1500

NOTE: Only use Catalog ID = "NA" for the Cable Adapter if you are requesting a Kit Type = O (Deadbreak Housing ONLY). A cable adapter is required to properly install the accessory onto a cable.

T3 – Kit Type

Catalog ID	Description	T Body	Connecting Plug	Epoxy Plug and Cap	Stud
O	Deadbreak Housing ONLY	1	–	–	–
E	Equipment Connection (For future apparatus bushing)	1	–	1	1
S	Splice (Splice cable using Deadbreak T-body)	1	1	1	1
T	Tap Kit (Add-on, for adding to “S” kits for multi-tap splice or adding another cable to existing installation).	1	1	–	1
D	Dead End Splice (With future add-on capability).	1	–	2	1

T4 – Grounding and Sealing Kits

Catalog ID	Cable Adapter Sizes	Cold Shrink Tube	#6 Ground Braid with Drain Wire	Constant Force Spring
NG	–	–	–	–
S4100	H – R	1	–	–
GS4102	H – K	1	1	1
GS4103	L – M	1	1	1
GS4104	N – Q	1	1	1
GS4105	R	1	1	1

NOTE: When working with jacketed cable it is recommended to re-seal the bottom of the Deadbreak T body with a sealing kit. Depending on the cable construction and local installation practices, the cable neutrals may also require special treatment. For jacketed cables like tape shielded cable, a ground braid should be used to connect the shield to ground without disturbing the integrity of the seal. If you are unsure if or which kit to include, please contact your Prysmian representative.

NOTE: Grounding and Sealing Kits can be ordered as part of the Deadbreak T Body kit or separately. Contact your Prysmian representative for details

T5 – Recommended Lugs

Catalog ID	Connector Type	Cable Size		Conductor Material	Current Rating
		Stranded / Compressed	Compact / Solid		
ALSB1L1	Shear Bolt	#5 - 300		Bi-Metallic (AL / CU)	600 / 900
ALSB1L2	Shear Bolt	1/0 - 450		Bi-Metallic (AL / CU)	600 / 900
ALSB1L3	Shear Bolt	3/0 - 600		Bi-Metallic (AL / CU)	600 / 900
ALSB1L4	Shear Bolt	350 - 800		Bi-Metallic (AL / CU)	600 / 900
ALSB1L5	Shear Bolt	600 - 1250		Bi-Metallic (AL / CU)	600 / 900
ALSB1L6	Shear Bolt	1250 - 1600		Bi-Metallic (AL / CU)	600 / 900

NOTE: If you need a compression connector, please contact your Prysmian representative and provide the conductor size, material, stranding. This information is critical for selecting an appropriate connector for the application.

T6 – Cable Cleaning “PREP” Kits

Catalog ID	HP Cleaning Pad	Drying Pad	180-Grit AL Oxide Abrasive Cloth
NP	–	–	–
1P	1	1	1

NOTE: Cable preparation and cleaning is critical for the install and operation of any medium voltage accessory. If you do not have access to suitable cleaning supplies, it is recommended a cleaning kit be included. It is critical that cleaning pads are not reused to clean other cables, so consider how many phases you will be preparing with the kit requested when selecting how many cleaning items are needed.

Accessories

Deadbreak Basic Insulating Plug

The Deadbreak Insulating Plug provides a means for insulating a 35kV Deadbreak Elbow or Bushing Extender. The Insulating Plug has an internal threaded contact that engages a threaded stud. The Deadbreak Insulating Plug is available with an Aluminum (600A) or Copper contact (900A). Each Insulating Plug has a molded-in hex nut used for installation. The hex nut also doubles as a capacitive test point. Included with every Insulating Plug is a low-profile EPDM rubber cap that is installed onto the molded-in hex nut. The cap features an eyelet for installation and removal and reduces stack height, which is important in environments where space is limited.

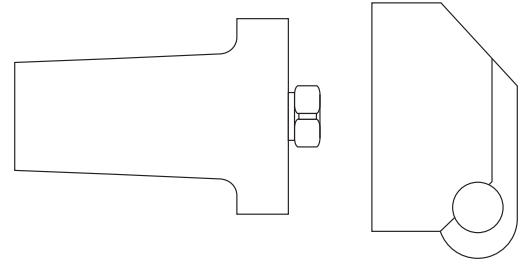

A1 – Deadbreak Basic Insulating Plug and Cap

Catalog ID	Current Rating	Voltage	Interface	Epoxy Plug	Cap	Stud
635BIP	600A	35kV	IEEE 386 Interface 13	1	1	-
935BIP	900A	35kV	IEEE 386 Interface 13	1	1	-
635BIP-LS	600A	35kV	IEEE 386 Interface 13	1	1	1
935BIP-LS	900A	35kV	IEEE 386 Interface 13	1	1	1

Deadbreak Connecting Plug

The Deadbreak Connecting Plug provides a means for connecting two or more 35kV Deadbreak Elbows together. The Deadbreak T Bodies can be configured as a splice or stacked onto a junction or apparatus bushing. The Deadbreak Connecting Plugs are available with an Aluminum (600A) or Copper contact (900A). Each plug is manufactured from EPDM rubber, fully shielded, and has an internal 5/16" hex for installation.

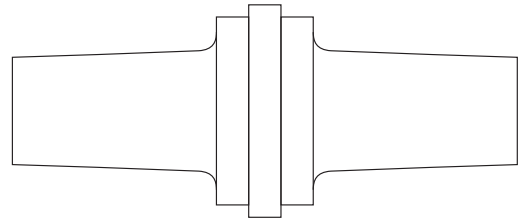

A2 – Deadbreak Connecting Plug

Catalog ID	Current Rating	Voltage	Interface
635CP	600A	35kV	IEEE 386 Interface 13
935CP	900A	35kV	IEEE 386 Interface 13

Deadbreak Threaded Stud

The Deadbreak Threaded Stud provides a means to bolt together IEEE 386 Deadbreak products together. The Stud is available in Aluminum (600A) or Copper (900A). Both studs are tin-plated.



A3 – Deadbreak Threaded Stud

Catalog ID	Current Rating	Voltage
635STUD	600A	35kV
935STUD	900A	35kV



na.prysmian.com

ACS-DS-0024-1224

Follow us

