

TIS 402 Addendum 2: Additional Instructions for Splicing Lifeline® MC Cables with Four 2AWG Conductors and Four 10AWG Grounding Conductors Using Ceramic Standoffs and Copper Grounding Bar



Scope

This addendum provides additional installation instructions for splicing four conductor 2AWG cables with 10AWG grounding conductors, part numbers LMC04002-0410 and LMCJ04002-0410. Most of the installation procedure of TIS 402 applies to these two constructions and this addendum only includes the necessary additional instructions which are related to proper termination of the four 10AWG grounding conductors.

Material Needed and Not Supplied

- Copper ground bar, IlSCO Cat. No D167-8
- Stainless steel bolt, 3/4" X 1/4-28
- Stainless steel split washer, 0.025" X 0.5"

Tools Needed

- Tap, 1/4-28
- Tap wrench
- Small flat head screw driver

Installation

Mounting Enclosure and Ceramic Standoffs

- Mounting holes should be drilled to maintain at least 1.75 inches center to center spacing for all components and 1.375-inch center to enclosure spacing for ceramic standoffs. The ground bar should be aligned lengthwise with the cable installation orientation, parallel to and approximately one inch from the enclosure wall as shown in figure the the right.
- Prior to installing the ground bar, a 14-28 tap should be run through the two partially threaded holes.
- Install components with bolts through panel. Split washers should be installed between bolt head and panel. Ceramic standoffs required 1/4-20 bolts and ground bar requires 3/4 inch long 1/4-28 bolts.

Securing Cable

- Remove 16 inches of armor for sufficient conductor length within enclosure to run and terminate ground conductors.

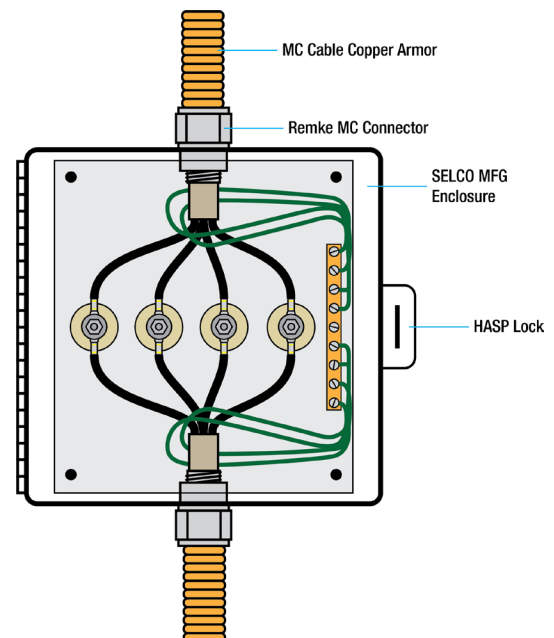

Lifeline MC Cable*

* When ordering the Lifeline® MC Splice kit, please specify by **adding** the prefix **CUS** to the Part Number (Kit P/N: CUSLMC04002-0410)

Part Number	Conductor Size (AWG/MCM)	Number of Conductors	Nom. Core Diameter (in)	Nom. Armor Diameter (in)	Remke Connector (Cat. No.)	Remke Connector Hub Size (in)	Recommended Enclosure Size (IN x H x D)
LMC04002-0410	2 and 10	4 4	1.20	1.58	RTKSS-125-10	1-1/4	10 x 10 x 6

Jacketed Lifeline MC Cable*

* When ordering the Lifeline® MC Splice kit, please specify by **adding** the prefix **CUS** to the Part Number (Kit P/N: CUSLMCJ04002-0410)

Part Number	Conductor Size (AWG/MCM)	Number of Conductors	Nom. Core Diameter (in)	Nom. Armor Diameter (in)	Nom. Overall Cable Diameter (in)	Remke Connector (Cat. No.)	Remke Connector Hub Size (in)	Recommended Enclosure Size (IN x H x D)
LMCJ04002-0410	2 and 10	4 4	1.20	1.58	1.70	RTKSS-125-10	1-1/4	10 x 10 x 6

Thomas & Betts Blackburn® Copper Compression Connector for 2AWG Conductor

- Use Cat Number: 54107 (Note: connectors are included in splice kit)

SELCO MFG NEMA 4X Enclosure

Enclosure (W x H x D)	SELCO MFG Model Number
10 x 10 x 6 - inch	NE4X-10-10-06-BP