

Installation Instructions for Lifeline® QFCI Optical Fiber Cables



Technical Information Sheet #601

Installation Guideline for QFCI

The details of cable construction and cable properties can be obtained on data sheet TIS #600

Pulling of the Cable

For minor pulling forces (200-500 N) a pulling sleeve can be used. However if larger pulling force is required, the force must be transferred to the central strength member.

Bending

Minimum bending diameter is 250 mm. The individual fiber tubes can be bent down to a diameter of 100mm.

Dismantling – Each Element

Outer sheath

The sheath should be cut around in a circle at the required point. Then the cable should be bent carefully forth and back a couple of times. The sheath should/must be split before removal.

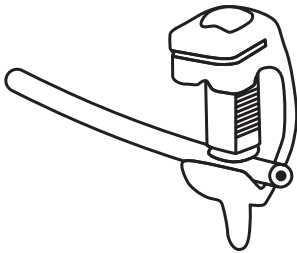

Removal of outer sheath can be done with a special circle cutting tool or with an ordinary knife since the layer under the sheath is steel wire braiding. This braiding will protect the cable core

Steel wire braiding

The braiding should be pushed backwards so the wires are accessible with a wire-cutting tool.

Glass tape (black color)

Unwind the tape and cut it with a suitable cutting tool.

Inner sheath

The sheath should **carefully** be cut around in a circle at the required point. Then the cable should be bend carefully forth and back a couple of times. The sheath can be split for easier removal. To avoid damage of fiber tubes, the sheath should not be cut completely through.

Glass tape (black color) on tubes

Unwind the tape and cut it with a suitable cutting tool.

Fiber tubes

The fiber tubes can easily be removed with a special stripping tool. The tool must ensure a complete cut trough the plastic without damage to the fibers.

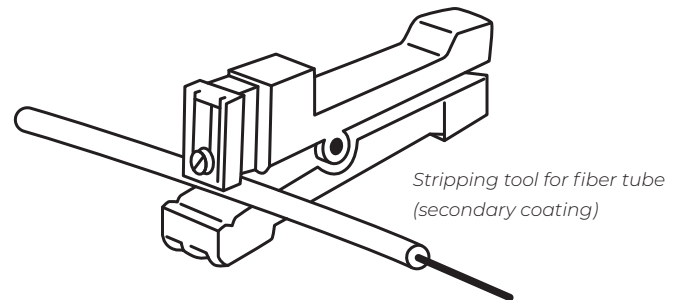

Primary coating on the fiber

A specially designed tool for removal of primary coating is necessary. The fibers can then be cleaned with a soft paper or clean textile cloth (gauze) moisten with pure spirituous.

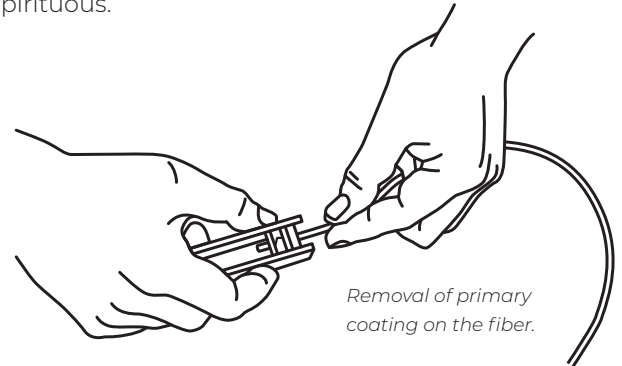

Central strength member - steel

The plastic coating can be removed by making a cut with a sharp knife and the pulled off by hand.